

A budapesti metró biztosítóberendezési és vonatirányító rendszere





Átszállóhely / Transfer
 Metróvonalak közötti átszállás
 On the metro network single



Vasútállomás / Railway station

Metróvonalak jellemzői

	M1 MFAV	M2 K-Ny	M3 É-D	M4 DBR
Vonalak hossza (km)	4.5	10.5	17.5	7.5
Állomások száma	11	11	20	10
Követés csúcsidőben	1'40''	2'20''	2'20''	2'30''
Utassok száma/nap	103 000	406 000	621 000	420 000

M1 vonal: 1896



Automatikus térközbiztosítás 1896.



1896-1973 (20 db)



**1973. Autostop
pályamágnes**

M1 rekonstrukció 1973. és 1996.



D55 alapú biztosítóberendezés + mágneses autostop Foglaltság: 100 kHz sínáramkör + számláló áramkör	1973
Elektronikus távvezérlő, KFM + KUD	1996



1973-tól

M2 vonal



Építés 2 szakaszban D67 biztosítóberendezés, ÖJÜ, aut. fordítás, KÖFI 125 Hz sínáramkör Elektromechanikus autostop	1950 - 1954 leállítás 1970-1972
Pálya és állomás rekonstrukció	2003-2007
22 új jármű	2012-2013

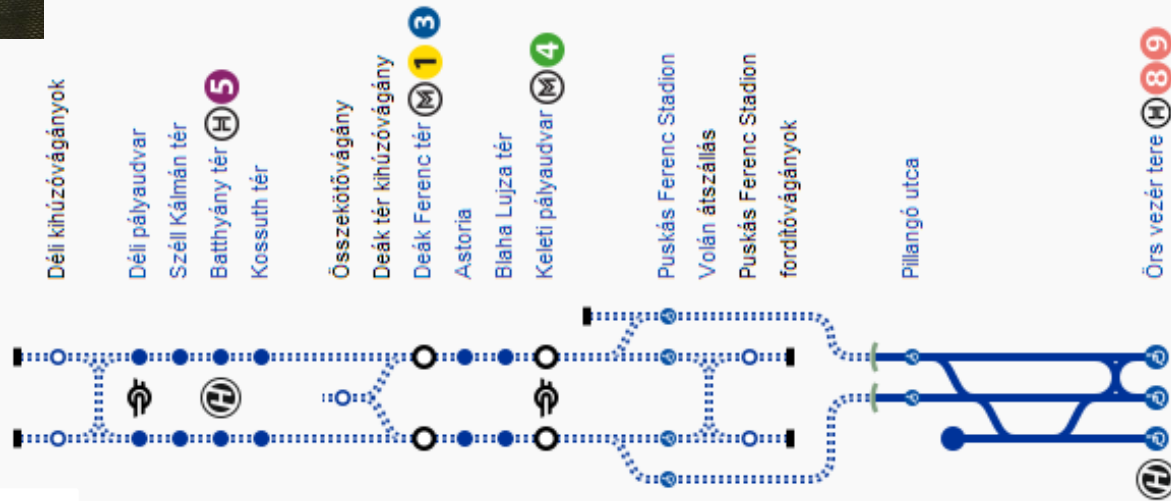

M3 vonal



<p>Építés 4 szakaszban D67 biztosítóberendezés, ÖJÜ, aut. fordítás, KÖFI 125 Hz sínáramkör Elektromechanikus autostop</p>	1976-1984
<p>Automatikus Vonatvezérlő Rendszer</p>	1986
<p>5. szakasz</p>	1990

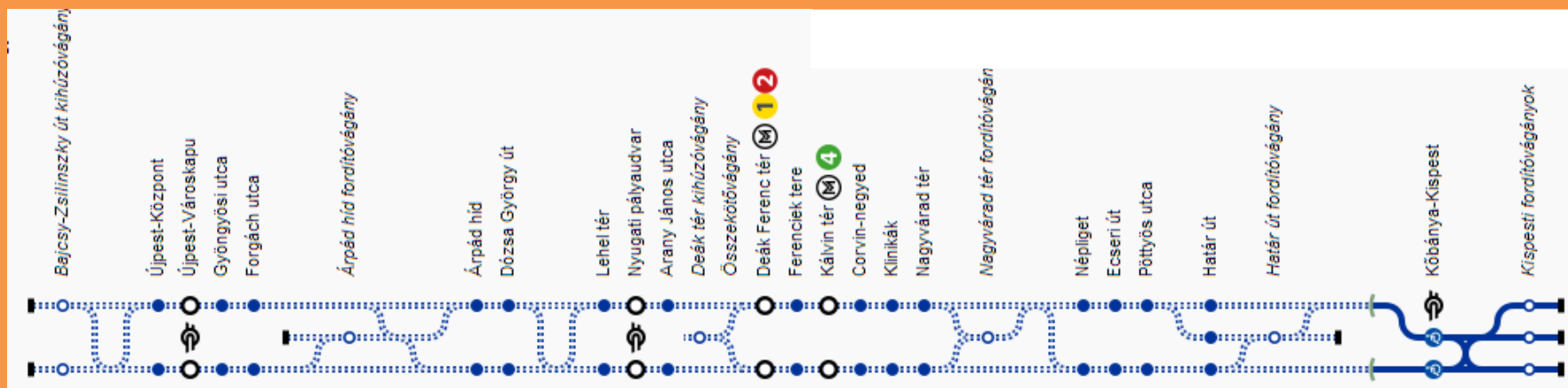

M2/M3 D67 biztosítóberendezés

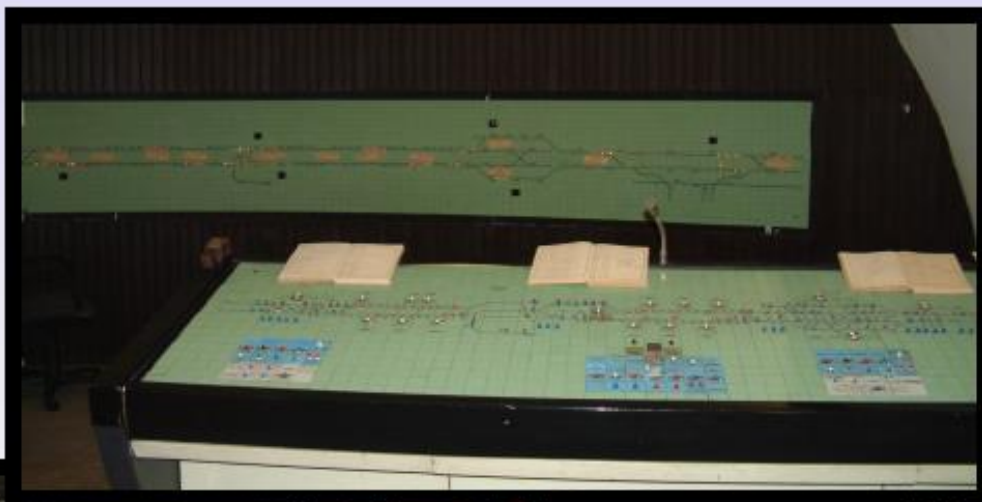

M2 kijáratí jelző + tolatásjelző



M2 Déli pu fordító vágányok



Körzetközpontok – M2

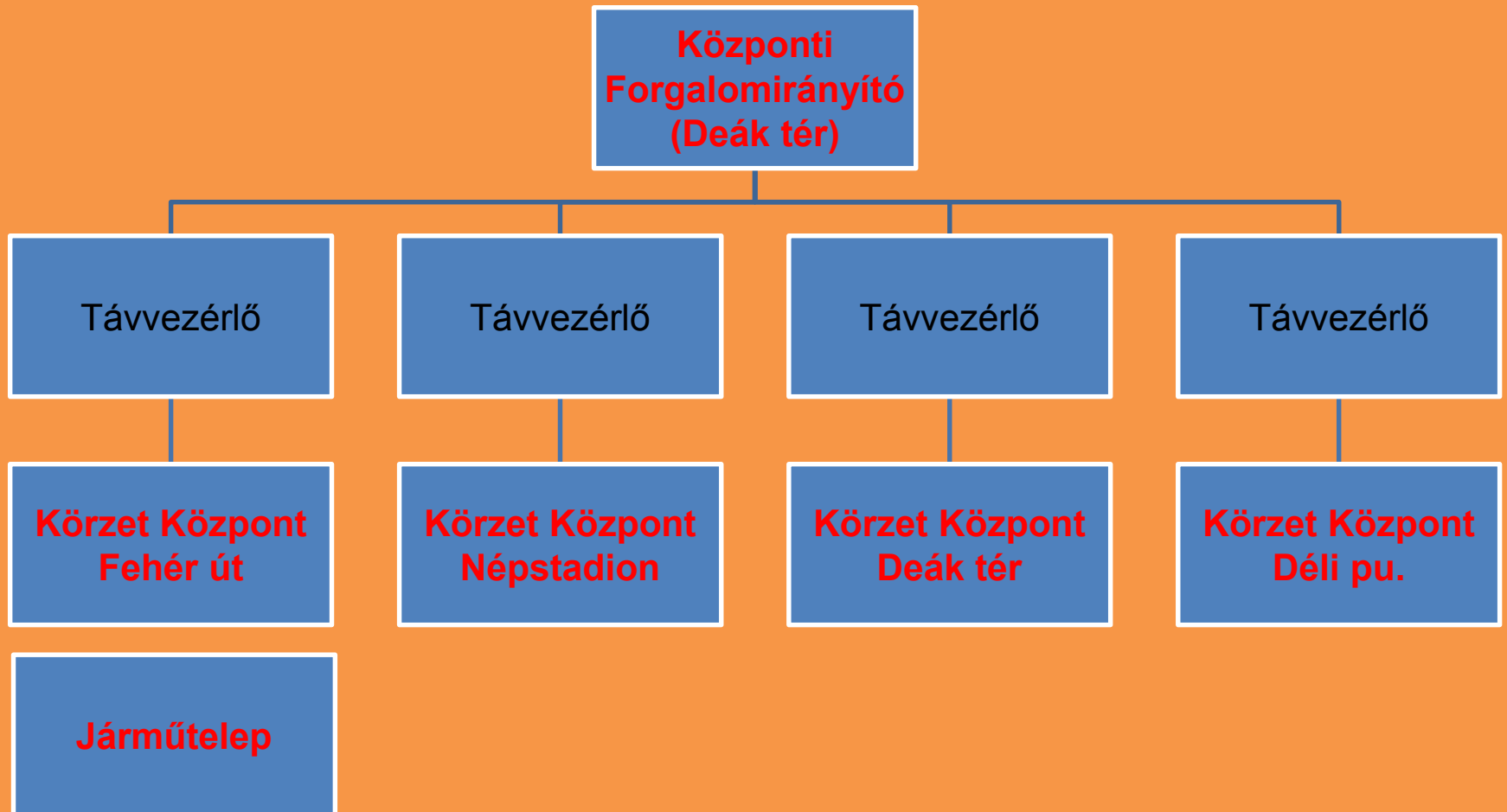

Körzetközpontok – M3

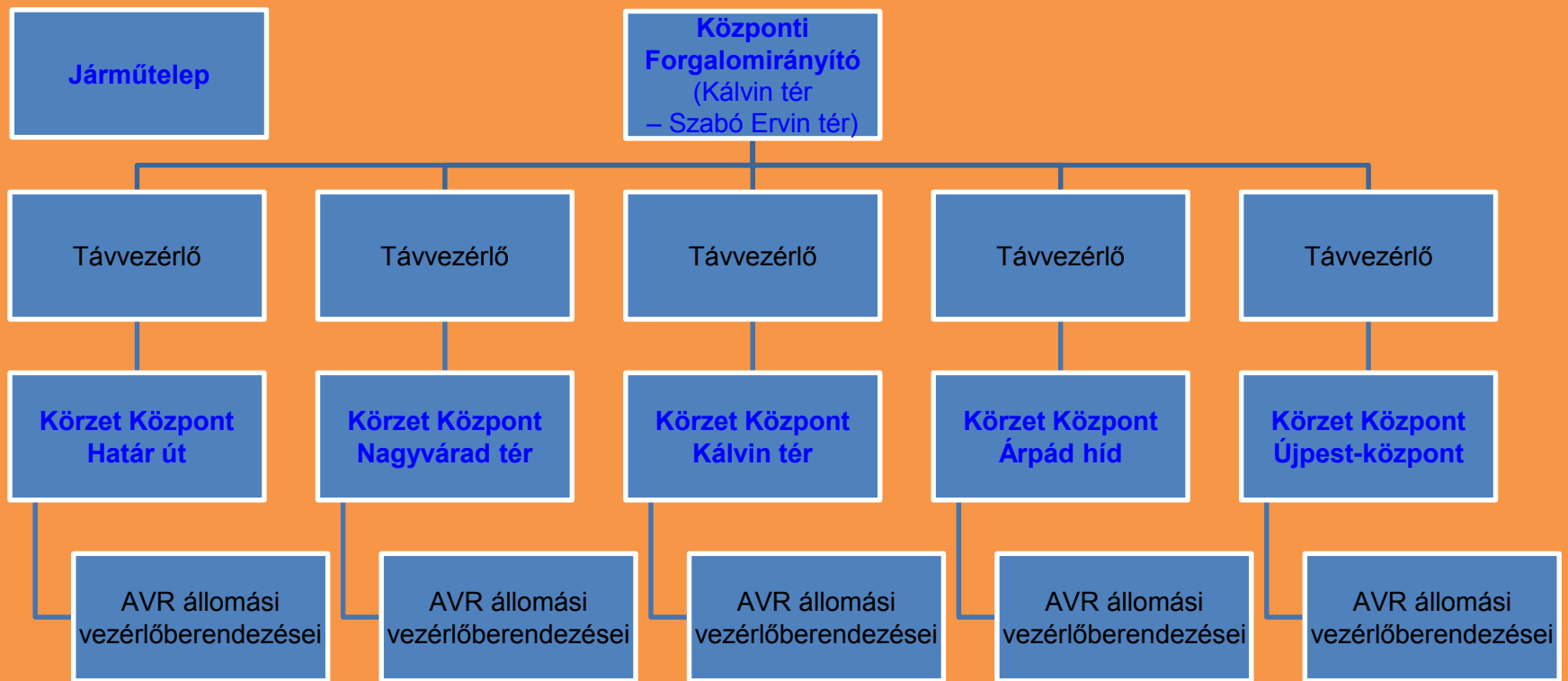

M3 Automatikusan Vezető Rendszer

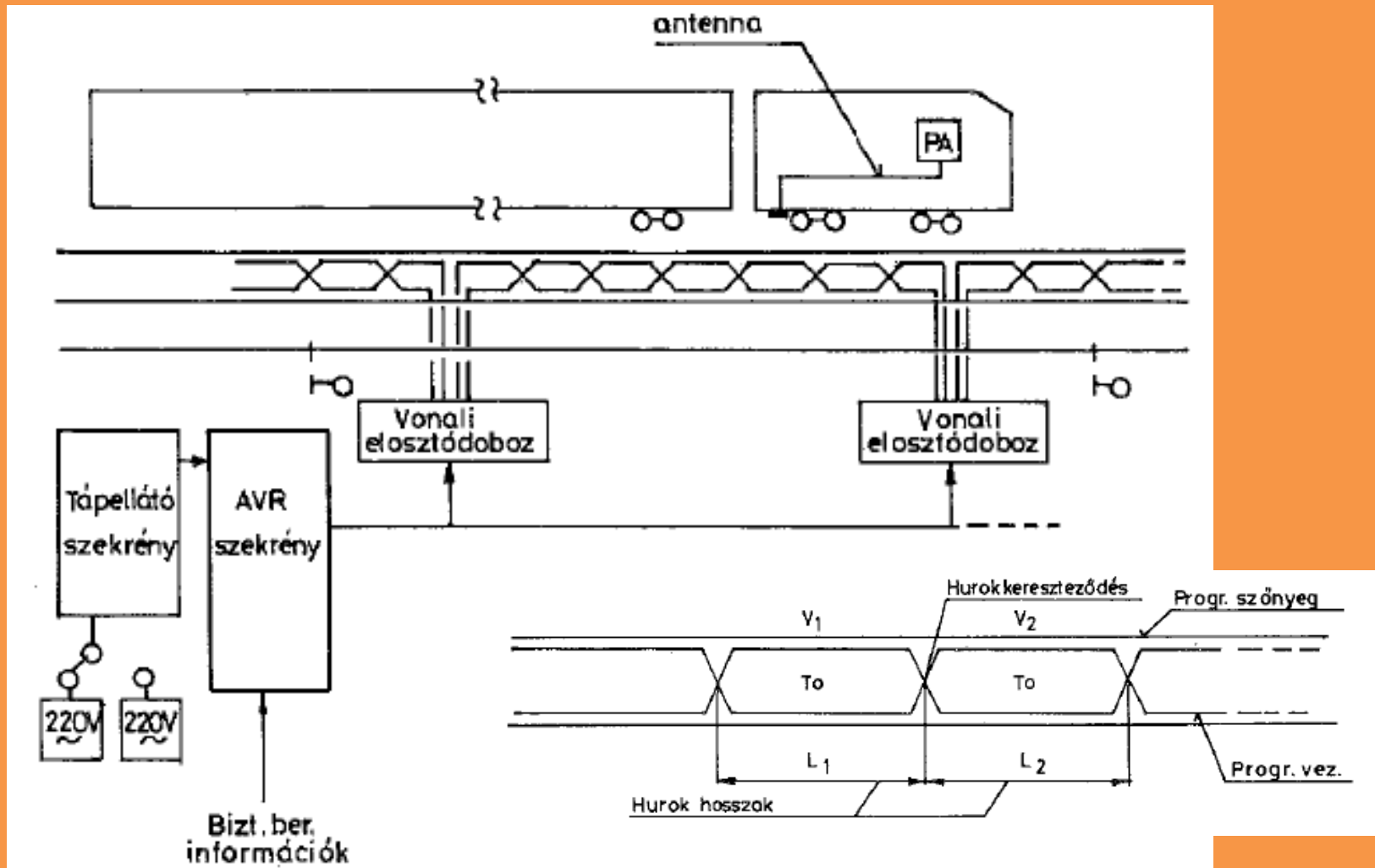



**M2 rekonstrukció
M4/DBR új építés**

M2 rekonstrukció



Pálya és állomás rekonstrukció	2003-2007
22 új jármű	2012-2013.
SICAS tengelyszámlálókkal + CBTC	2010-2013.
Próbaüzem utasok nélkül	2013.09/12.
Migráció, próbaüzem utasokkal	2013.12.

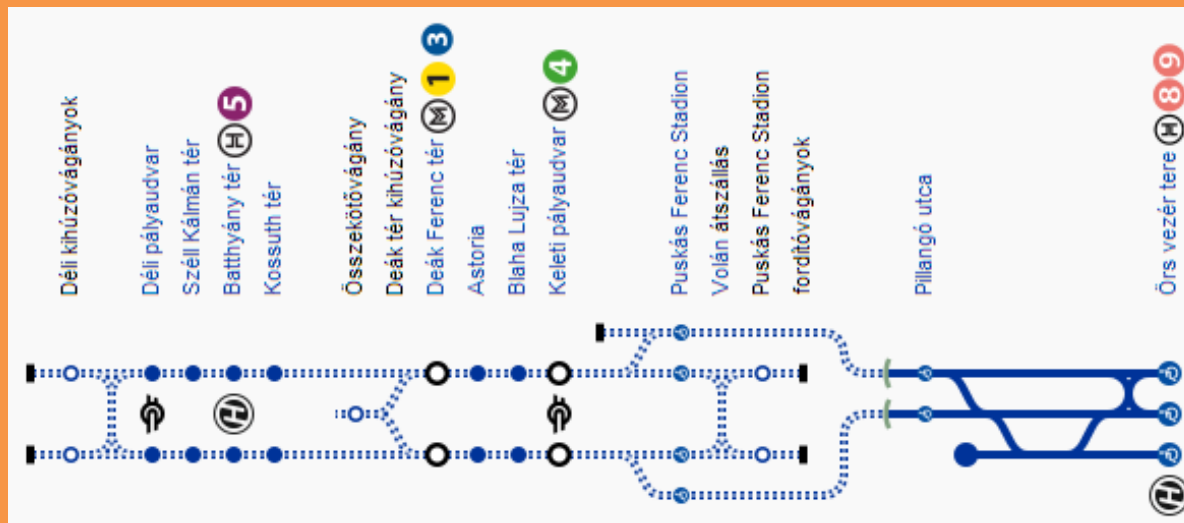

Éjszakai, hétvégi tesztek

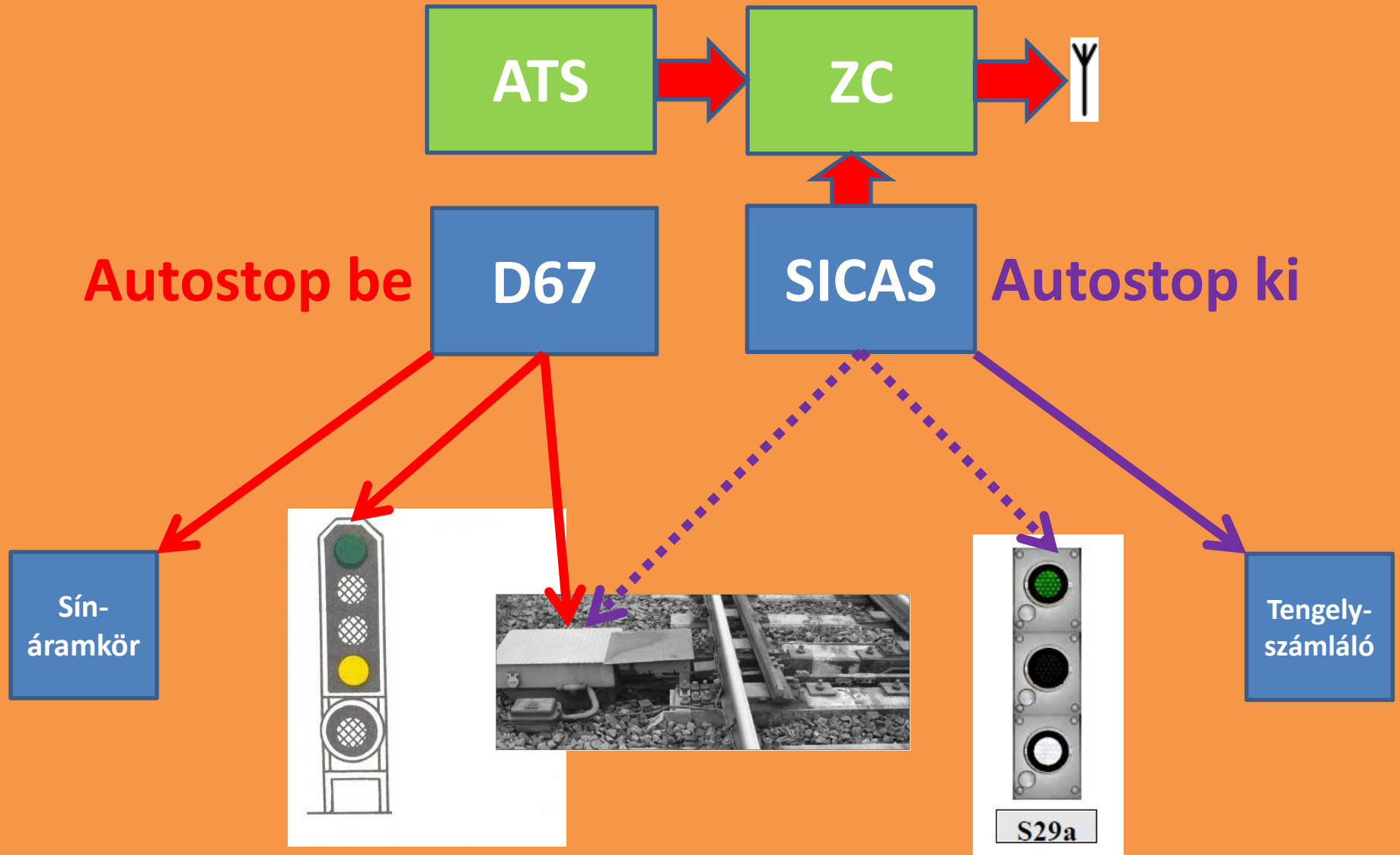

M4 vonal/DBR



Biztosítóberendezés feltétfüzet	2005.
15 jármű	2013.
Próbaüzem utasok nélkül	2013.12. – 2014.03.
1 éves utasforgalmi próbaüzem	2014.04.



SICAS PC + ECC

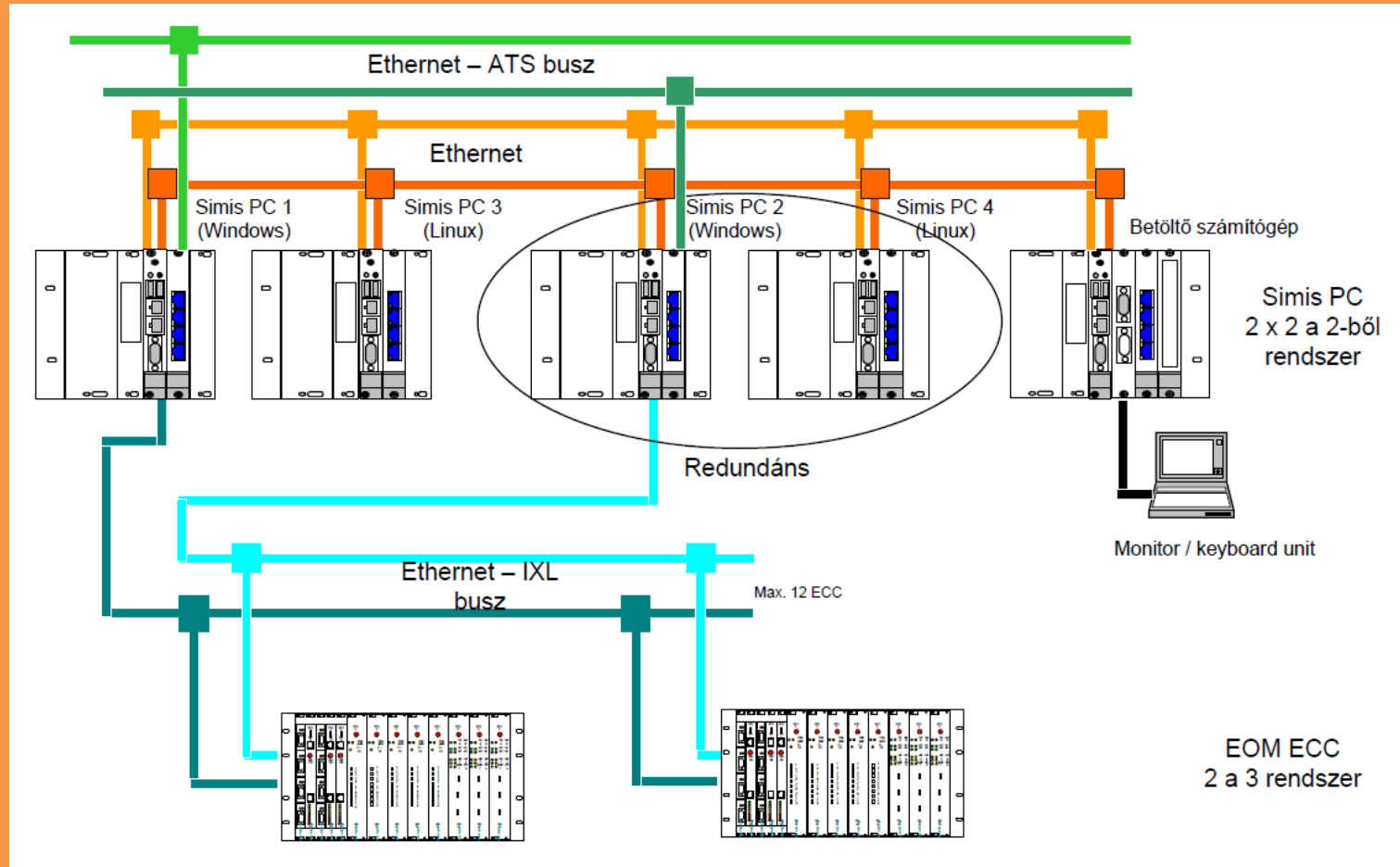

SIMIS 2003

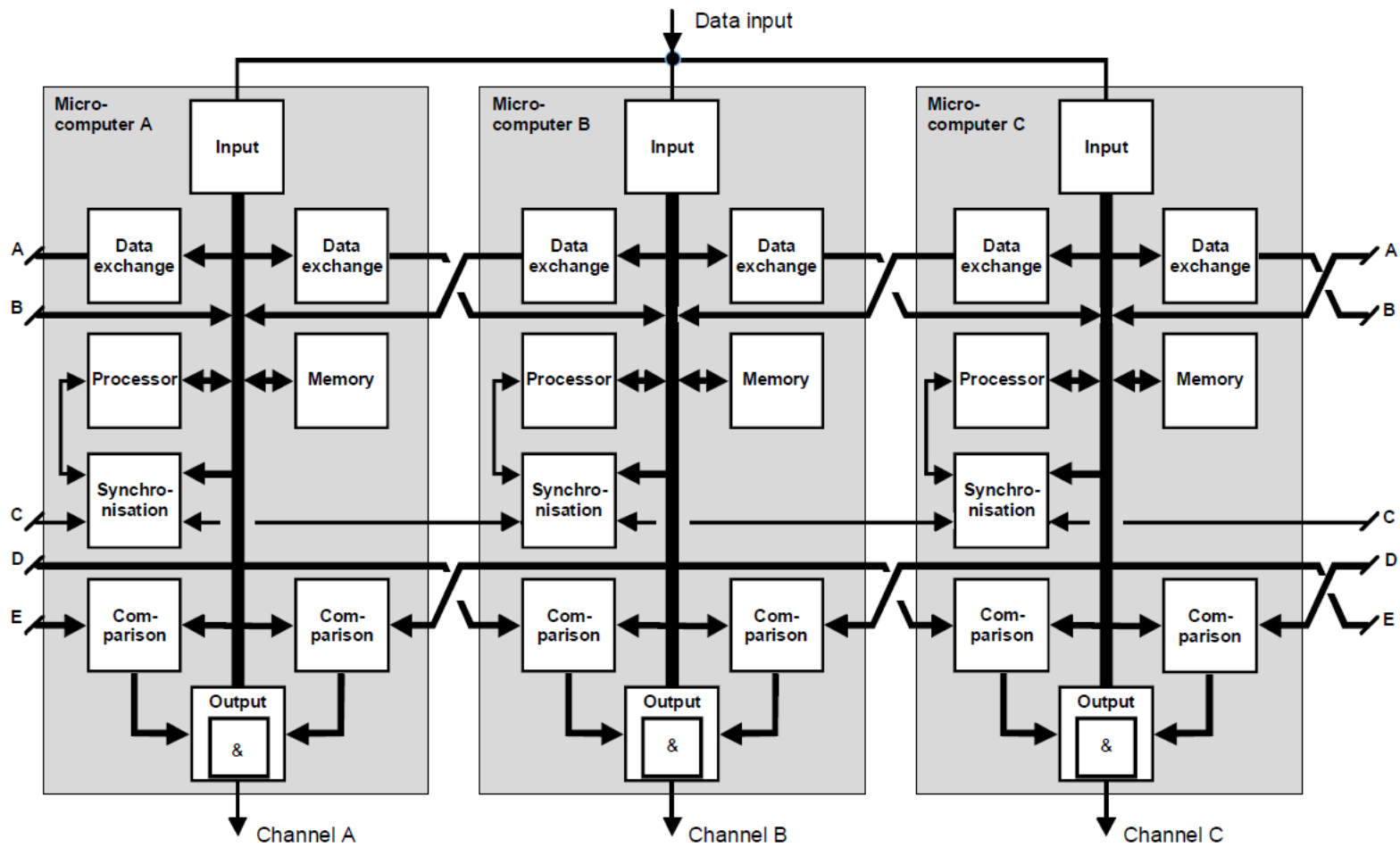

M2/M4 biztosítóberendezés belsőtér



M2/M4 biztosítóberendezés pályamenti eszközök



M2 SICAS

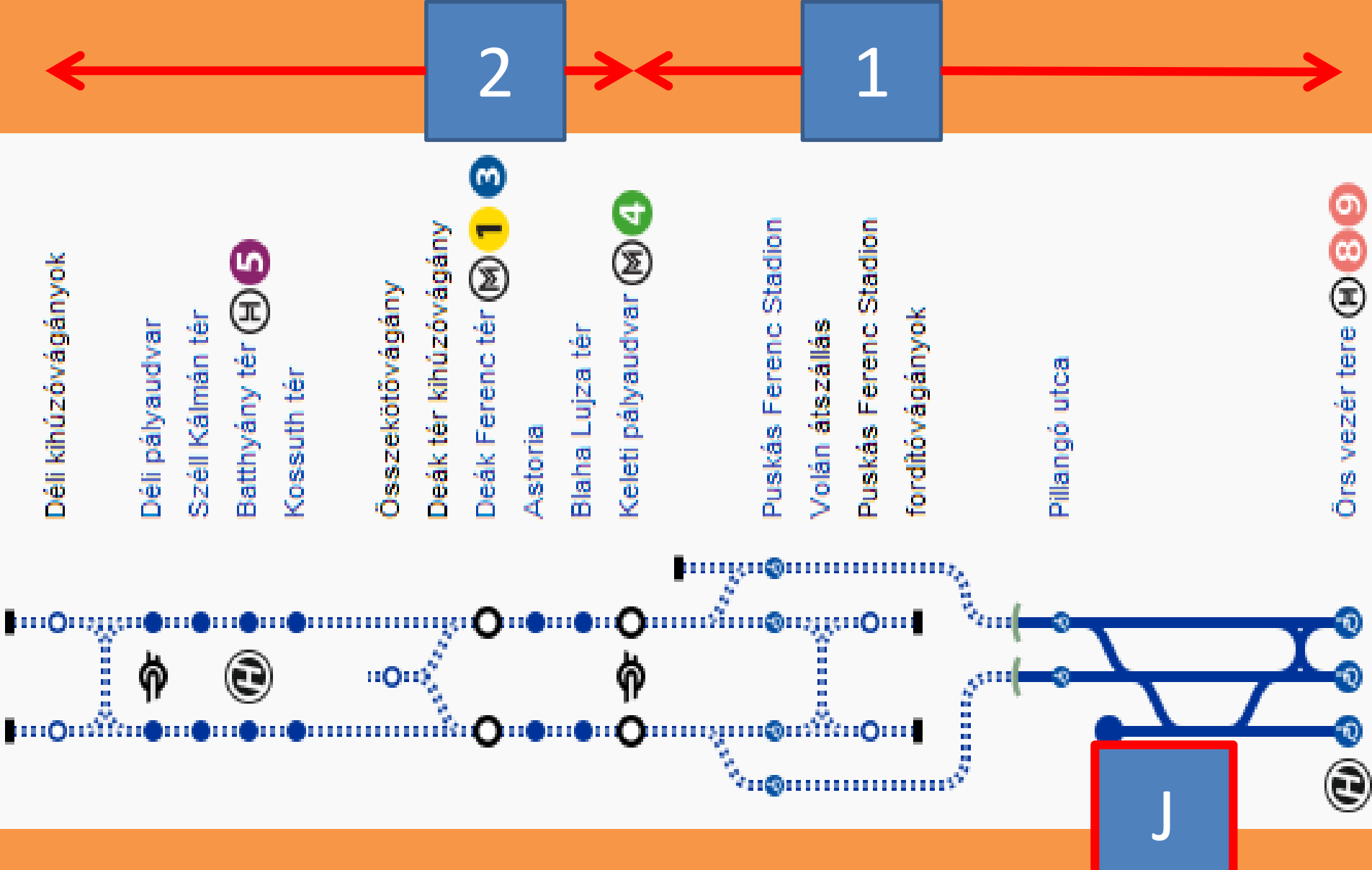

M4 SICAS

