

Robotpilóta Rendszerek

Vanek Bálint

Budapesti Műszaki Egyetem

2009. Április 22.

Temak

- Repulogep Szabalyzo rendszerek
- Hagyományos es Fly-by-wire rendszerek
- Automatizalas szintjei
 - FMS
 - AFCS
 - PFCS
 - ACE
- Megbizhatosag/ Redundans architectura

F-22 & Airbus 320 Fly-by-wire



Ha valami nem megy jól a szabalyzo rendszerekkel

Simple AC Controller Structure

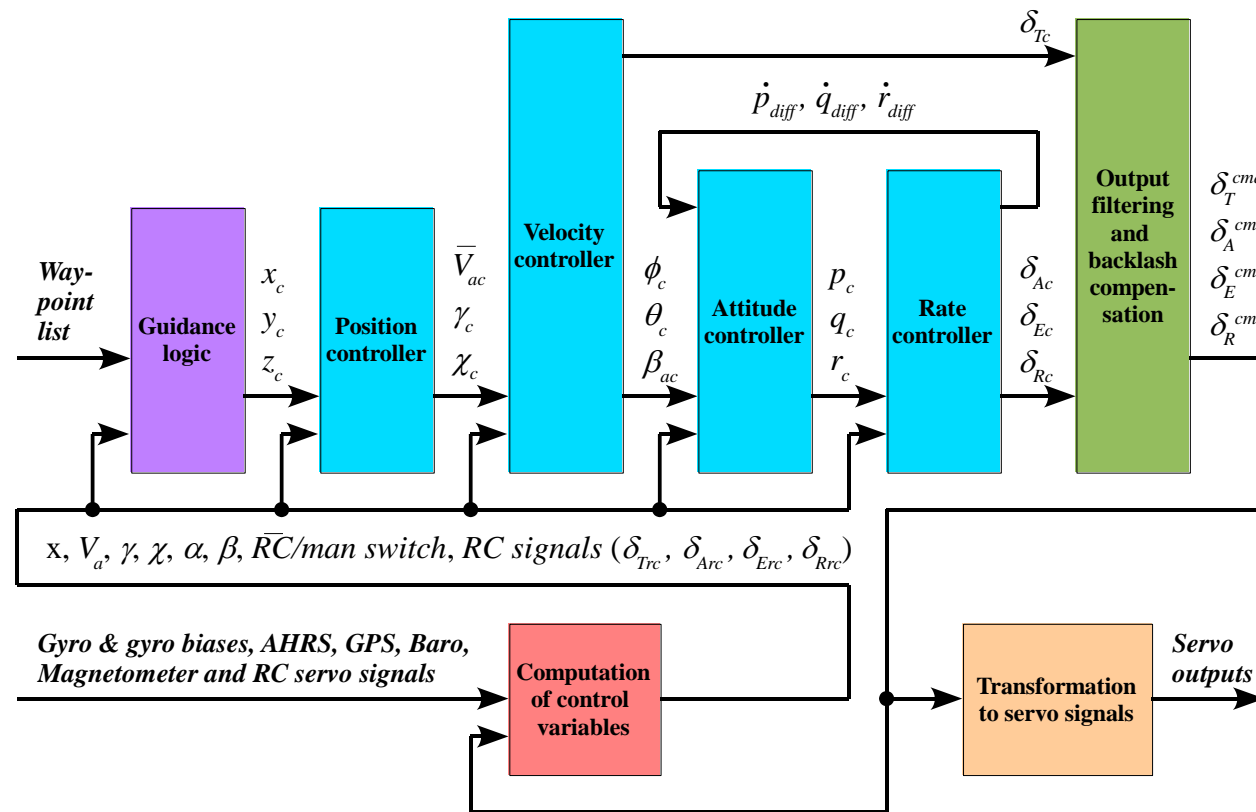

- **Position controller:**
 - It gets the waypoint position and sets the direction to it for use in the velocity controller
- **Velocity controller:**
 - It controls the direction and speed, where the aircraft flies.
- **Attitude controller**
 - It controls the roll, pitch and sideslip angles by commanding the angular rates to the rate controller
- **Rate controller**
 - It controls all three angular velocities by deflections of surfaces.
- **Output filter**
 - It holds same value until the input goes out of the desired range.
- **Backlash compensation**
 - Observes servo signal derivative and after its change I sends adds or subtracts backlash value.

Aircraft Motions during Flight

1. Pitch

2. Yaw

3. Roll

4. Climb / Descent

Yaw motion

The yaw axis is defined to be perpendicular to the plane of the wings with its origin at the center of gravity and directed towards the bottom of the aircraft.

A yaw motion is a movement of the nose of the aircraft from side to side.

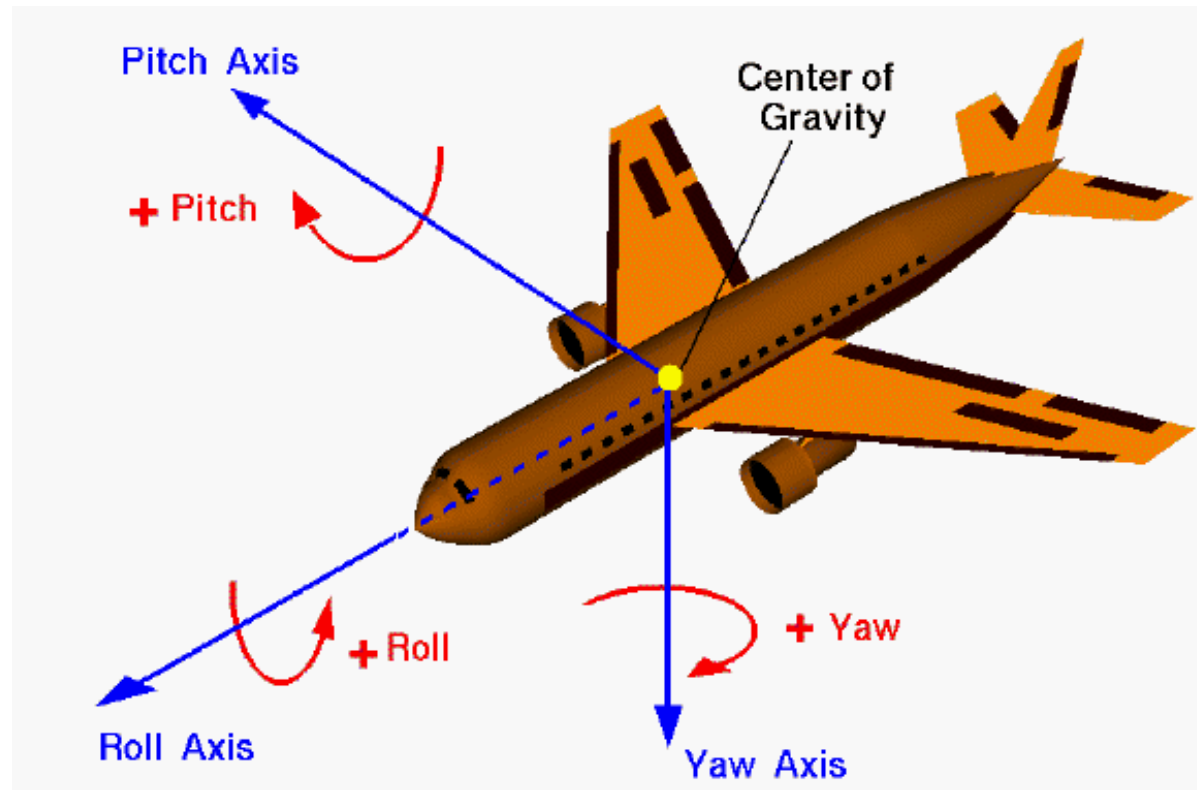

At the rear of the fuselage of most aircraft one finds a **vertical stabilizer and a rudder**. The stabilizer is a fixed wing section whose job is to provide stability for the aircraft, to keep it flying straight. **The vertical stabilizer prevents side-to-side, or yawing, motion of the aircraft nose.**

Vertical Stabilizer

The rudder is used to control the position of the nose of the aircraft. It is **NOT** used to turn the aircraft in flight

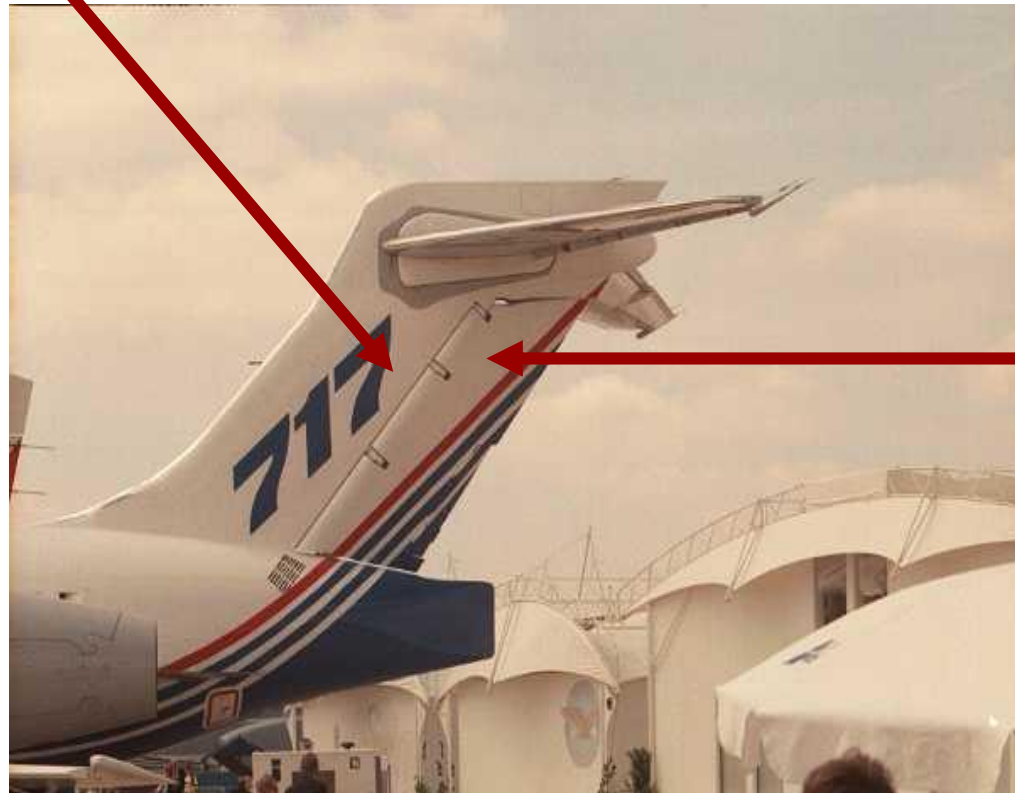

Rudder

Pitch motion

The pitch axis is perpendicular to the yaw axis and is parallel to the plane of the wings with its origin at the center of gravity and directed towards the right wing tip.

A pitch motion is an up or down movement of the nose of the aircraft.

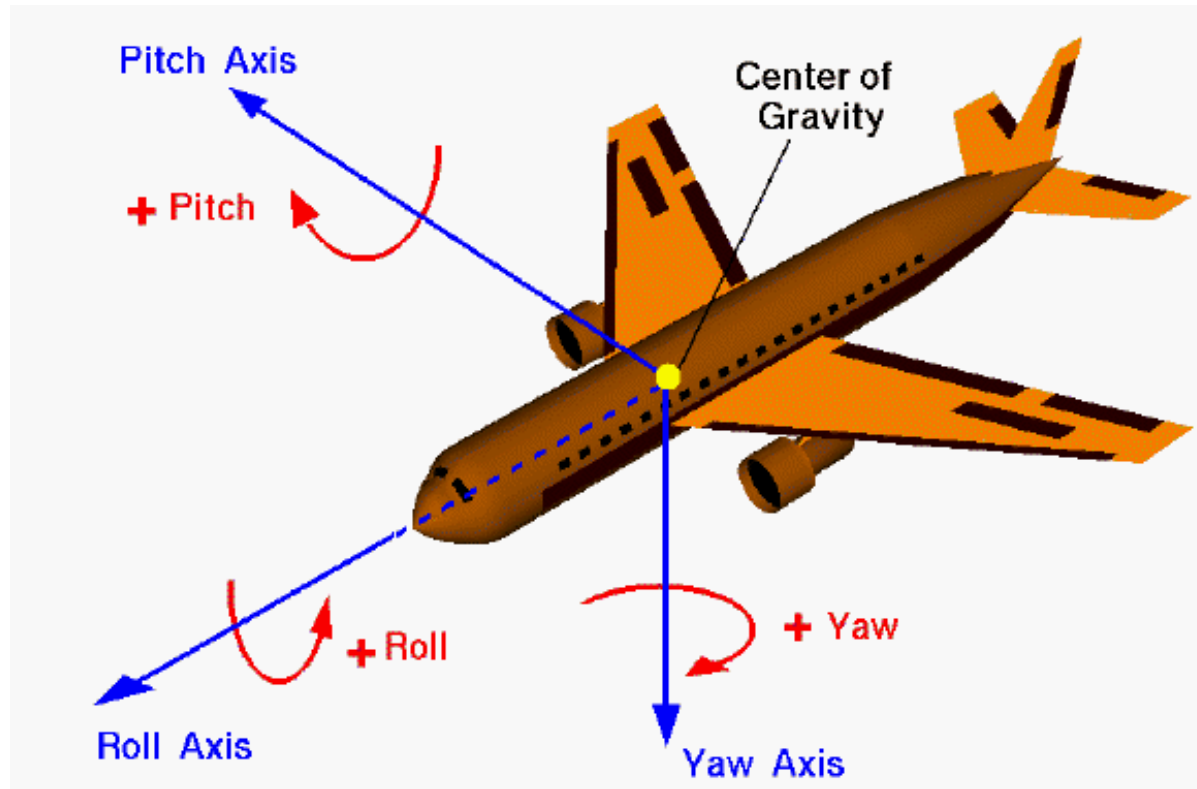

At the rear of the fuselage of most aircraft one finds a **horizontal stabilizer and an elevator**. The stabilizer is a fixed wing section whose job is to provide stability for the aircraft, to keep it flying straight. The **horizontal stabilizer prevents up-and-down, or pitching, motion of the aircraft nose**. Because the elevator moves, it varies the amount of force generated by the tail surface and is used to generate and control the pitching motion of the aircraft.

There is an elevator attached to each side of the fuselage. The elevators work in pairs; when the right elevator goes up, the left elevator also goes up. The elevator is used to control the position of the nose of the aircraft and the angle of attack of the wing. During take off the elevators are used to bring the nose of the aircraft up to begin the climb out. During a banked turn, elevator inputs can increase the lift and cause a tighter turn.



Roll motion

The roll axis is perpendicular to the other two axes with its origin at the center of gravity, and is directed towards the nose of the aircraft.

A rolling motion is an up and down movement of the wing tips of the aircraft.

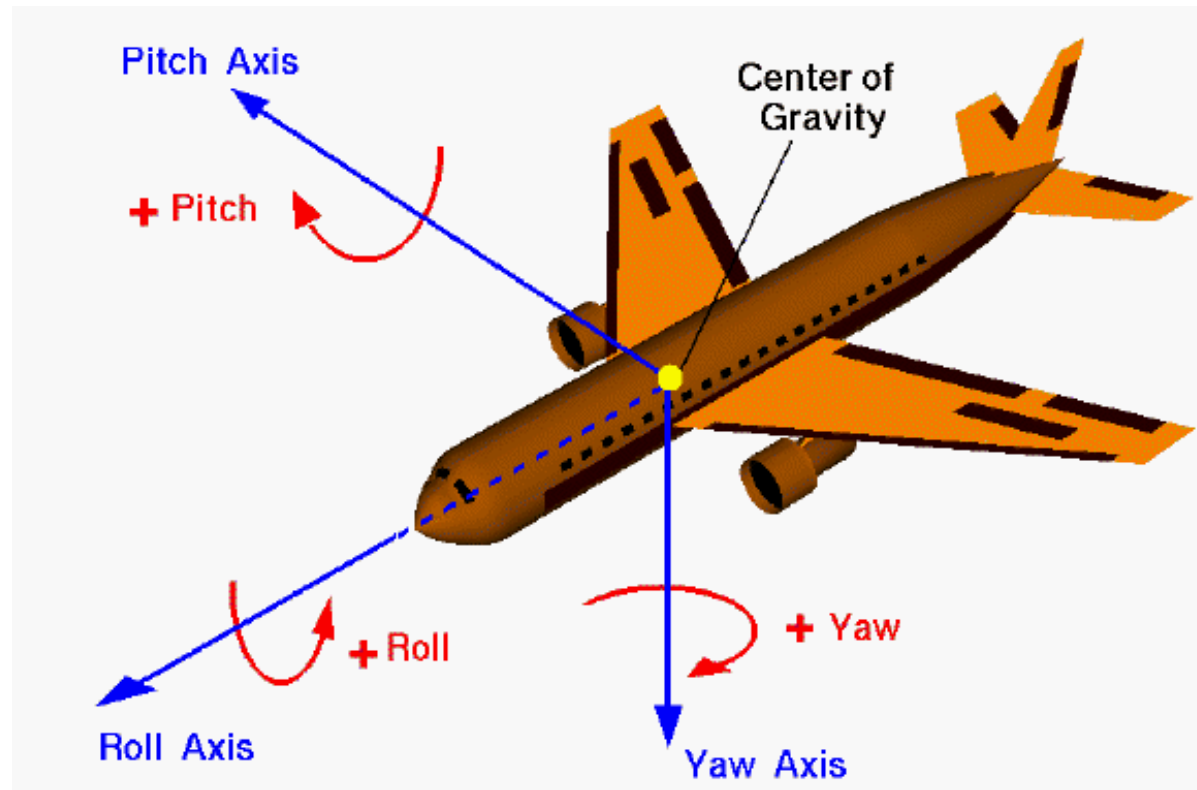

Ailerons can be used to generate a rolling motion for an aircraft. Ailerons are small hinged sections on the outboard portion of a wing. Ailerons usually work in opposition: as the right aileron is deflected upward, the left is deflected downward, and vice versa. The ailerons are used to bank the aircraft; to cause one wing tip to move up and the other wing tip to move down. The banking creates an unbalanced side force component of the large wing lift force which causes the aircraft's flight path to curve. (Airplanes turn because of banking created by the ailerons, not because of a rudder input. The ailerons work by changing the effective shape of the airfoil of the outer portion of the wing.





Spoilers are small, hinged plates on the top portion of wings. Spoilers can be used to slow an aircraft, or to make an aircraft descend, if they are deployed on both wings. Spoilers can also be used to generate a rolling motion for an aircraft, if they are deployed on only one wing.

Spoilers have two mode of operation

1. Spoiler Deployed on Only One Wing – This produces the rolling motion
2. Spoilers Deployed on Both Wings – This produces the braking action.

Turn Coordination

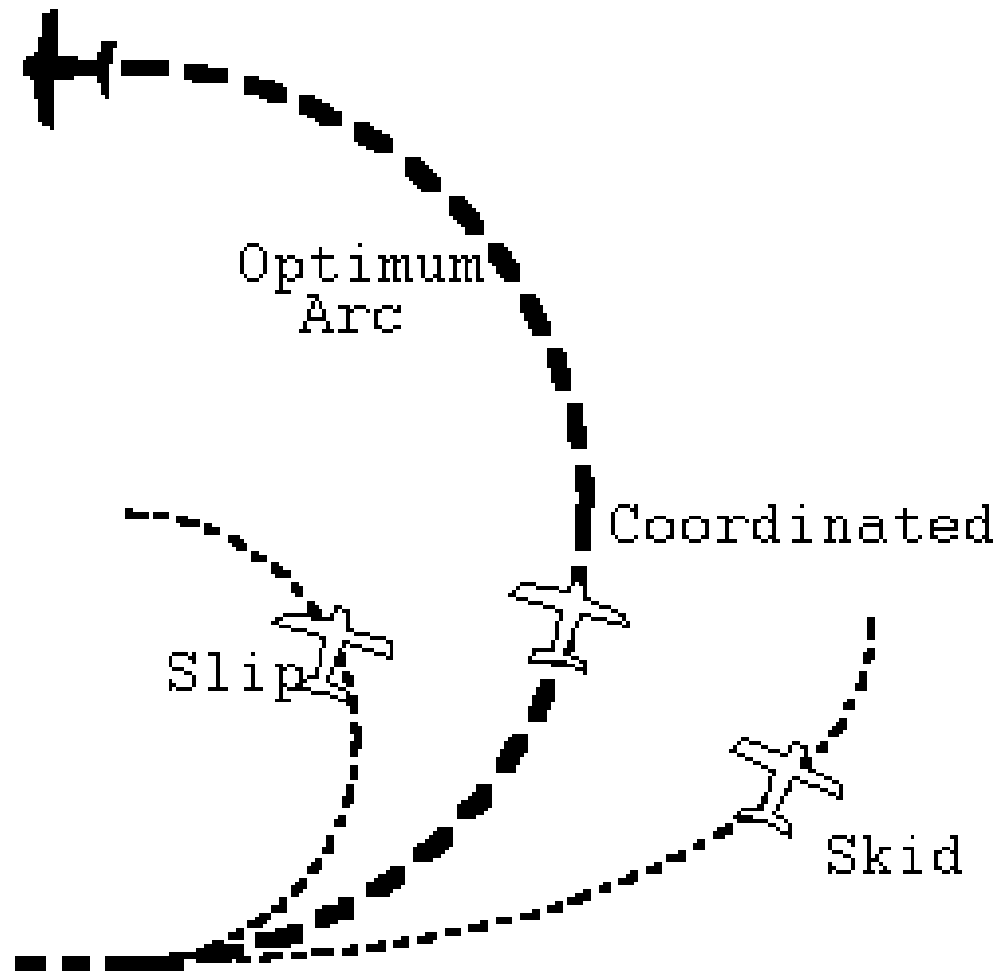

Climb / Descent

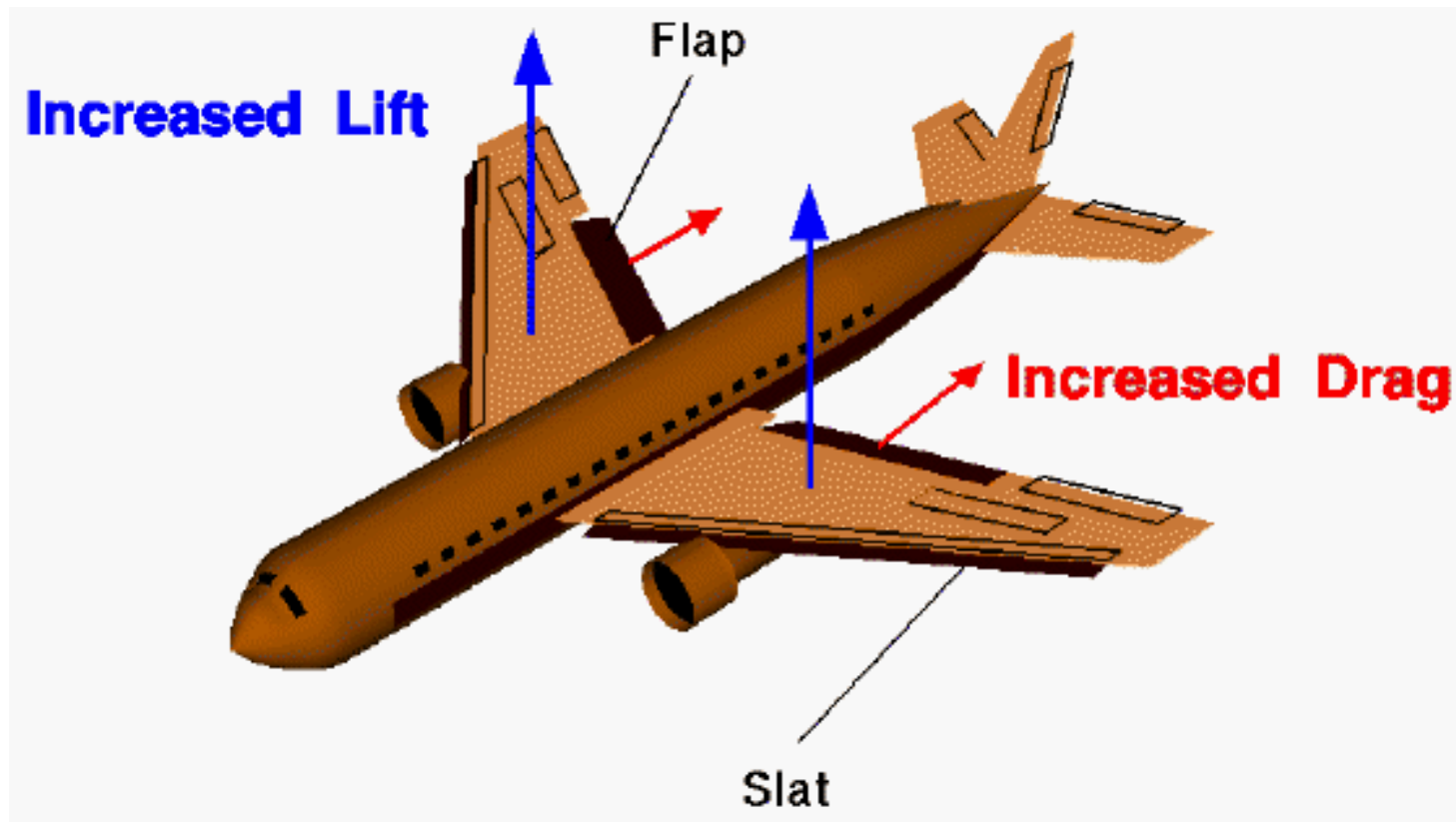

The amount of lift generated by a wing depends on the shape of the airfoil, the wing area, and the aircraft velocity.

F = Force

L = Lift

D = Drag



V = Velocity

Aerodynamic force is related to square of velocity.

$$F = \text{Constant} \times V^2$$

then

$$L = \text{Constant} \times V^2$$

Double the Velocity --> Quadruple the Lift

and

$$D = \text{Constant} \times V^2$$

Double the Velocity --> Quadruple the Drag

- Extending the flaps increases the wing camber and the angle of attack of the wing.

- This increases wing lift and also increases drag.

- Flaps enable the pilot to make a steeper descent when landing without increasing airspeed.

- They also help the airplane get off the ground in a short distance

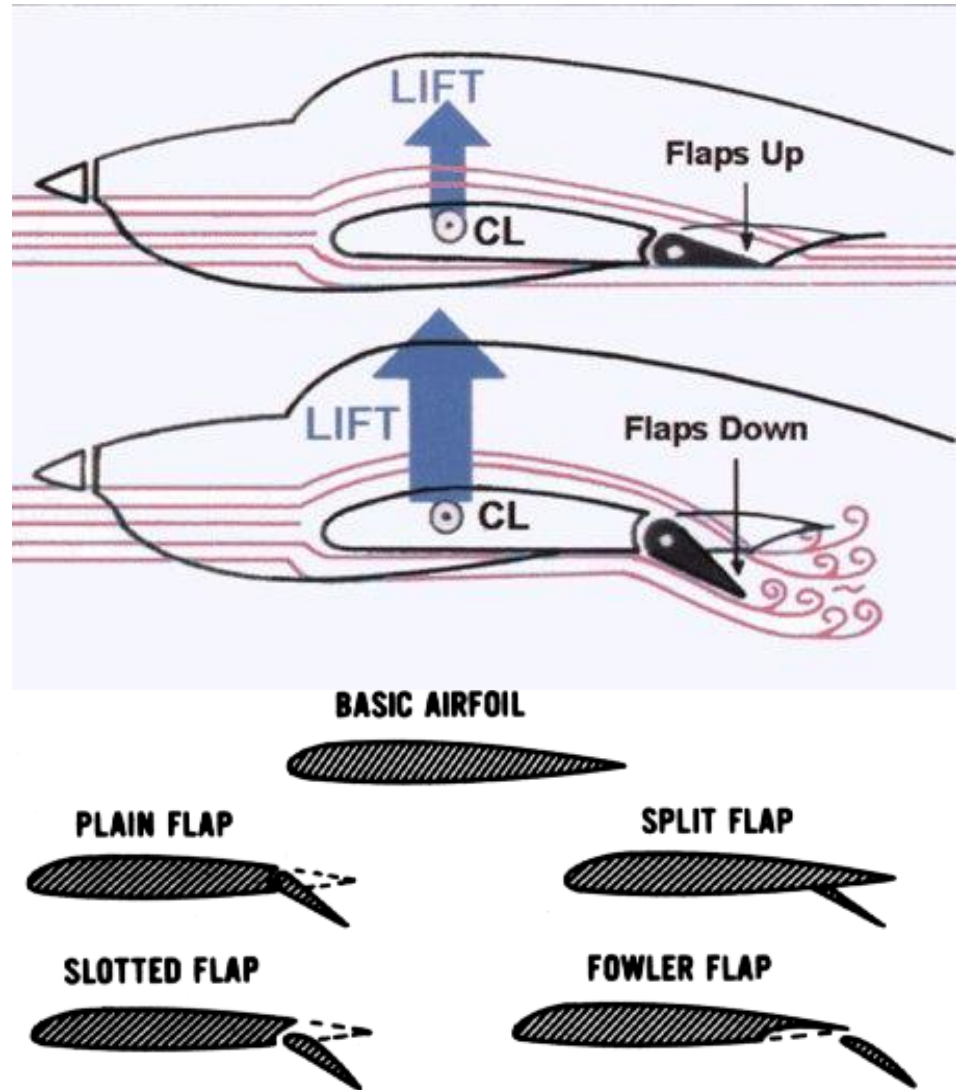

Effect of flaps and slats on Lift (B767)

- A 0.10 increase in lift coefficient at constant angle of attack is equivalent to reducing the approach attitude by one degree. For a given aft body-to ground clearance angle, the landing gear may be shortened for a savings of airplane empty weight of 1400 lb.
- A 1.5% increase in maximum lift coefficient is equivalent to a 6600 lb increase in payload at a fixed approach speed.
- A 1% increase in take-off L/D is equivalent to a 2800 lb increase in payload or a 150 nm increase in range.

Values of CL_{max} for some Boeing airplanes.

Model	CL_{max}
B-47/B-52	1.8
367-80/KC-135	1.78
707-320/E-3A	2.2
727	2.79
747/E-4A	2.45
767	2.45

Flight Control Systems

1. Conventional Control System

2. Fly-By-Wire Control System

3. FMS

4. AFCS

5. PFCS/SFCS

6. ACE

7. Hardware Redundancy Architecture

1. Conventional Control System

Flight Control System and its top level needs

- The flight control system is the system which controls the plane. This system consists of mechanical and electronic parts, and the pilot.
- It has to improve safety by means of a high degree of fault tolerance, and also by relieving the tasks of the pilot:
 - **Reduce** the pilot's **workload** by providing an intuitive user interface and by performing some functions automatically.
 - **Prevent** the crew from inadvertently **exceeding** the aircraft's controllability limits.
 - Act to **maintain** the aircraft within its normal **range of operation**.
 - Prevent the pilot from inadvertently entering a stall condition.
- Mission: The flight control system has to be highly unlikely to fail (effectively **fault tolerant**) so the plane can have safe flights.
- Use profile: The system has to operate during each flight (from takeoff to landing).
- Lifecycle: Same as lifecycle of the plane, which is somewhere around 20-30 years.

Flight Control System

- To achieve flight control **we require the capability to control the forces and moments acting on the vehicle**; if we can control these, then we have control of accelerations and hence velocities, translations and rotations.
- Direct mechanical linkages** were used between the pilot's cockpit controls (pitch/roll stick and rudder pedals) and the control surfaces that maneuver aircraft, which are : tail plane, ailerons and rudder.

Advantages

- This arrangement is inherently of **high integrity**, in terms of probability of loss of aircraft control, and provides us with a very **visible baseline** for explaining FCS developments.

Issues

- Pilot(s) work load is more
- Non-optimized handling qualities
- Maintenance costs are high.

Mechanical Flight Controls

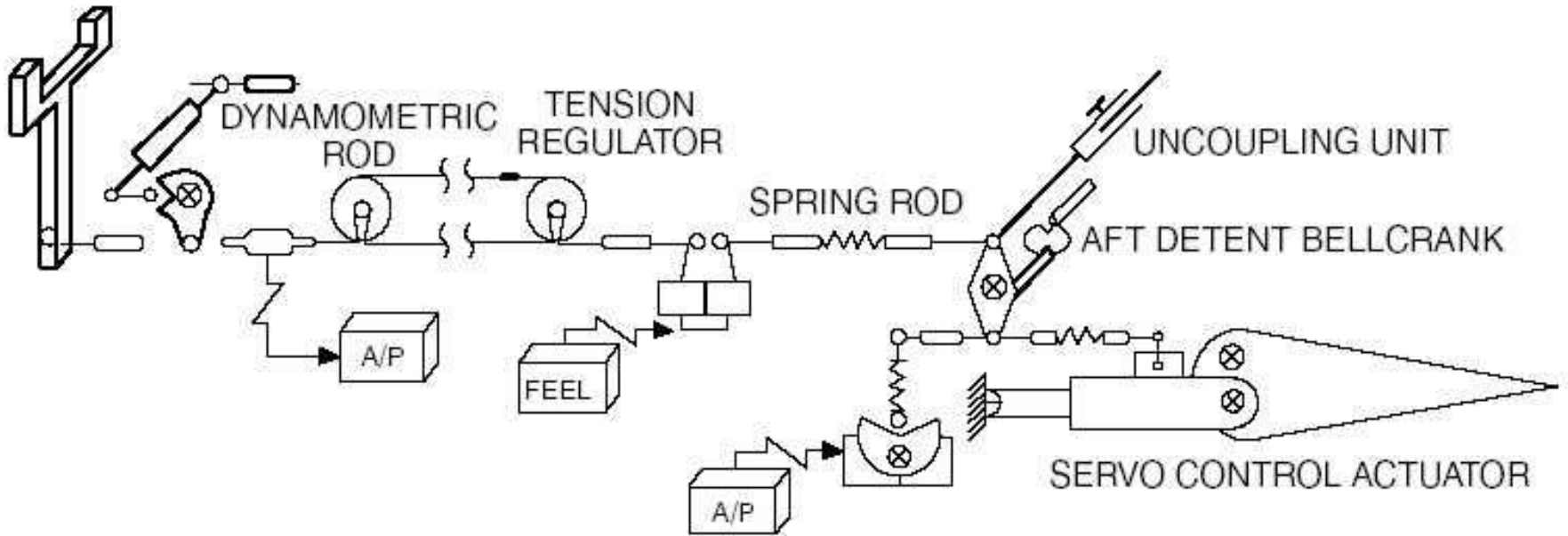

On aircraft of the A300 and A310 type, the pilot commands are transmitted to the servo-controls by an arrangement of mechanical components (rods, cables, pulleys, etc.). In addition, specific computers and actuators driving the mechanical linkages restore the pilot feels on the controls and transmit the autopilot commands

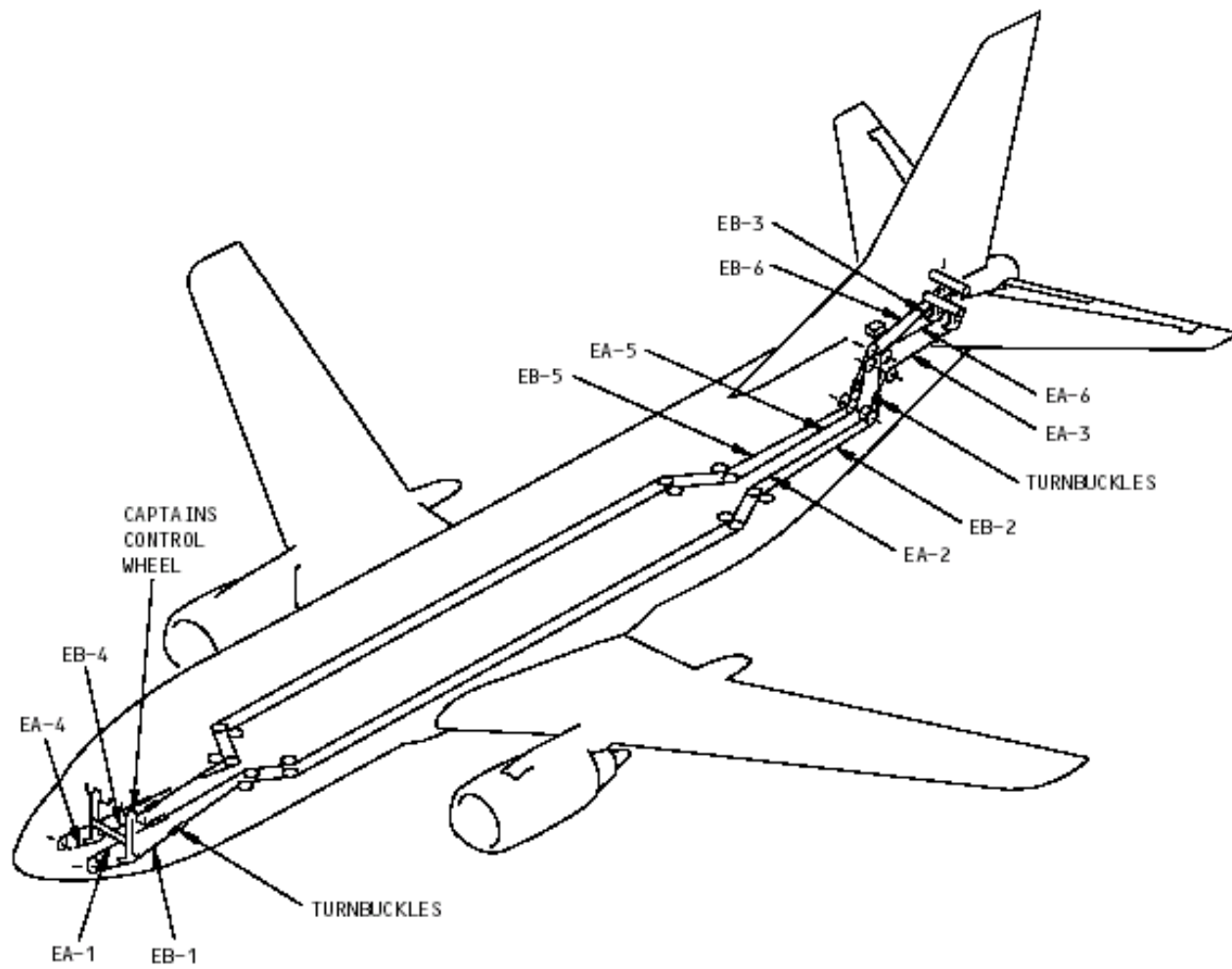

2. Fly-By-Wire Control System

Electrical Flight Controls - FBW

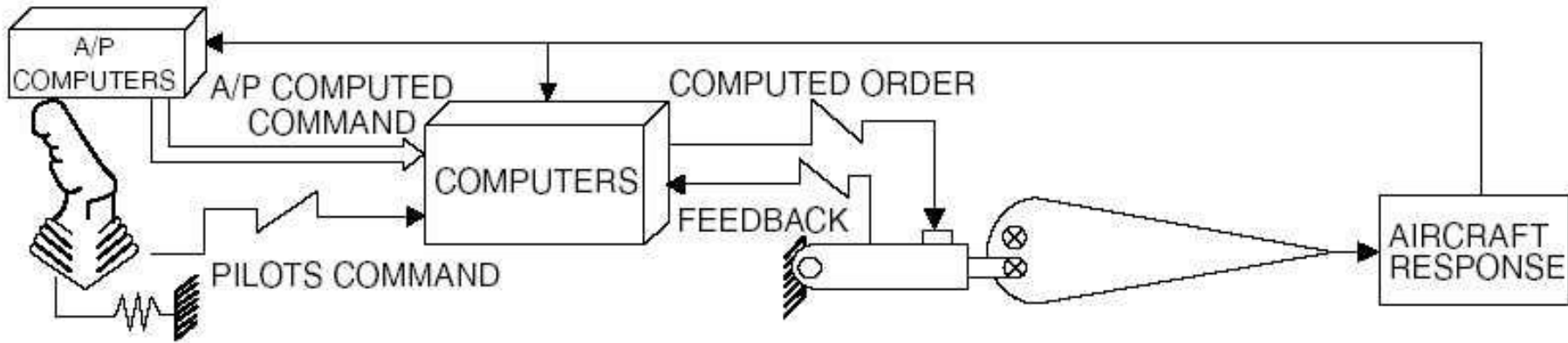

- Fly By Wire technology is used for **Primary Flight Control System**, which provides:
 - **Protections** against over speed, stall and structural overstress,
 - **Stability augmentation**,
 - **Auto trim** function,
 - Pilot controls **adaptation**,
 - Aerodynamic **configuration optimization**.
- Primary Flight control surface position orders are:
 - Electrically commanded,
 - Performed by actuators (either hydraulically or electrically powered).

Flight Controls

- Electric signal command hydraulic actuation

Pilot or autopilot control inputs command the PFCs to generate control surface commands.

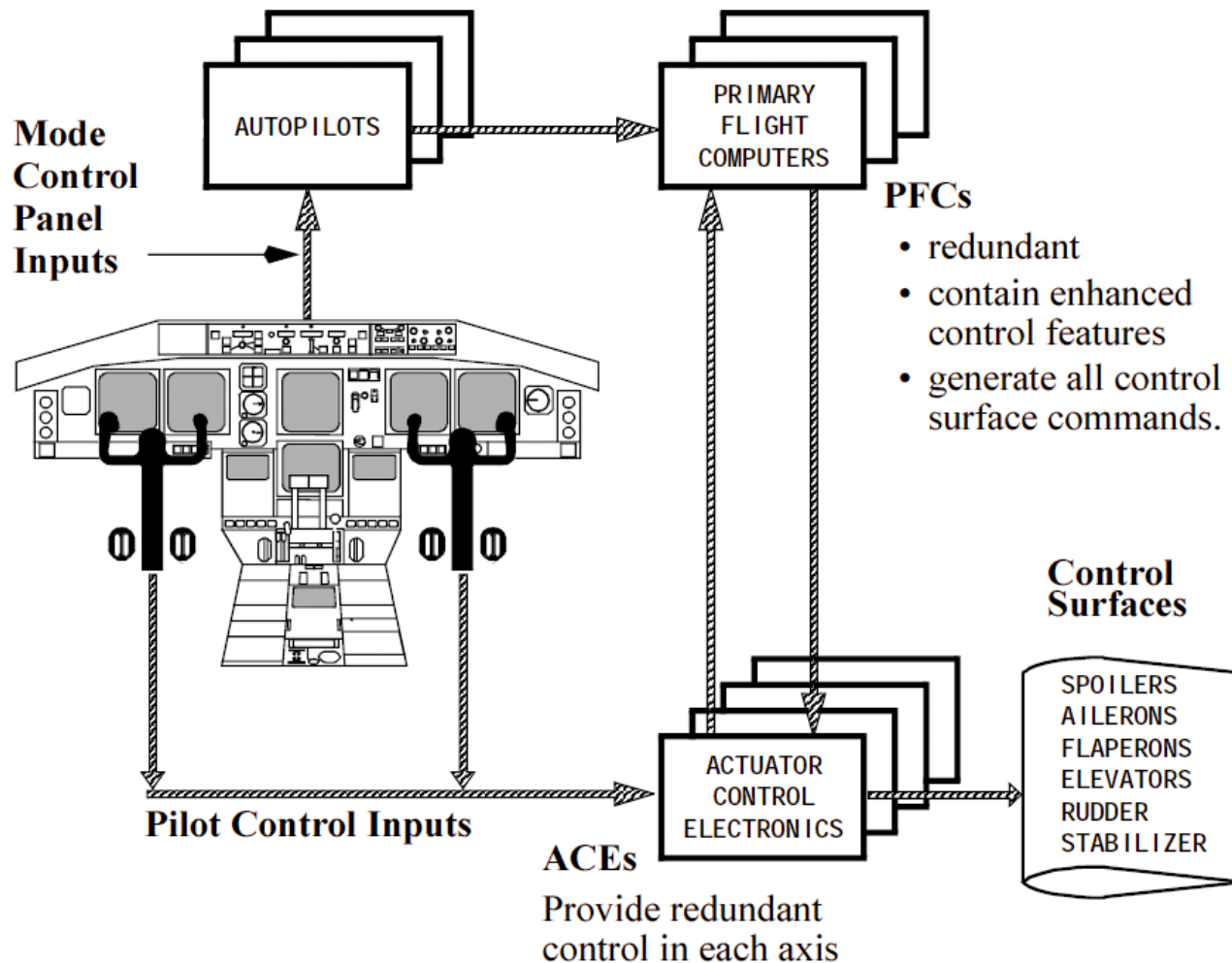

Electric signal command hydraulic actuation

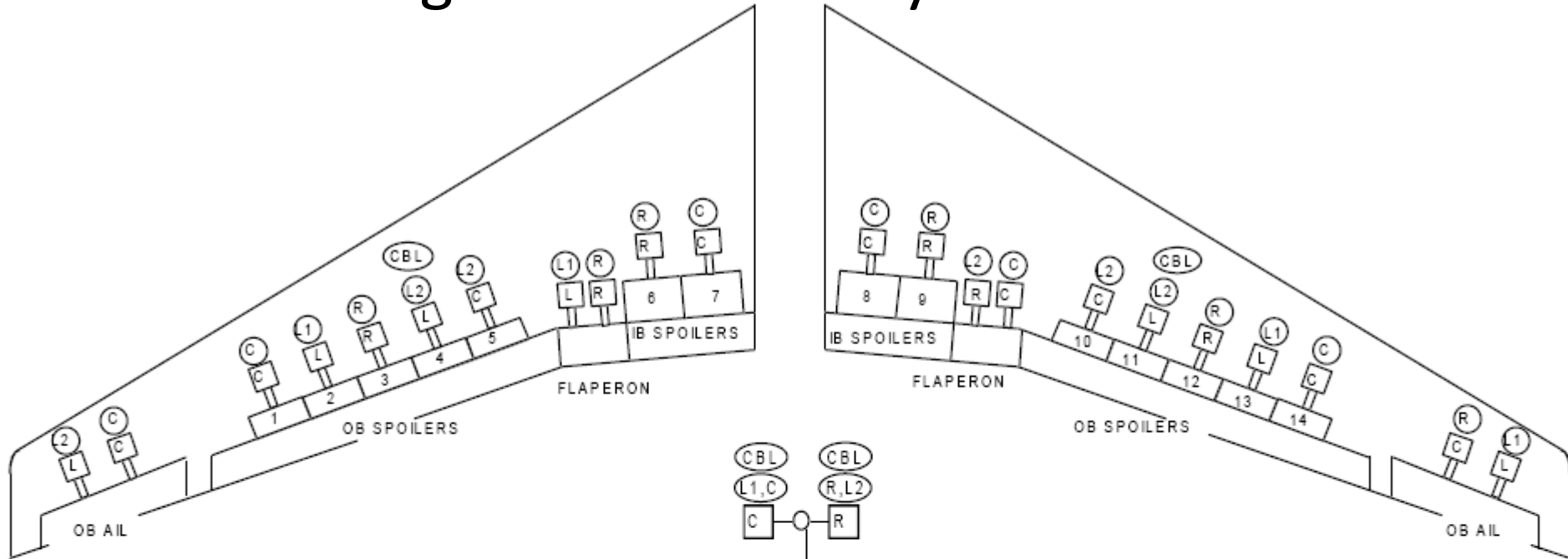

L1, L2, C, R DENOTES ACE SOURCE

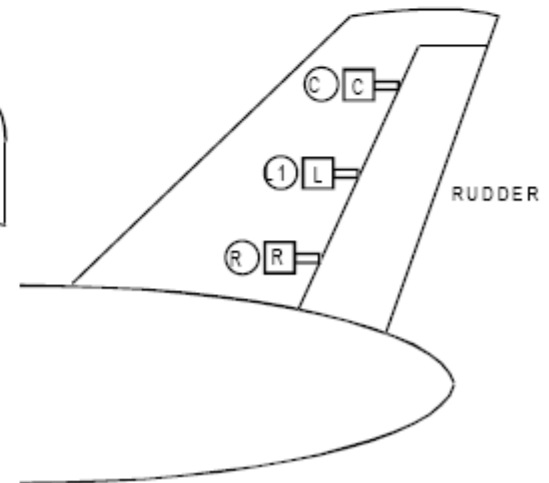
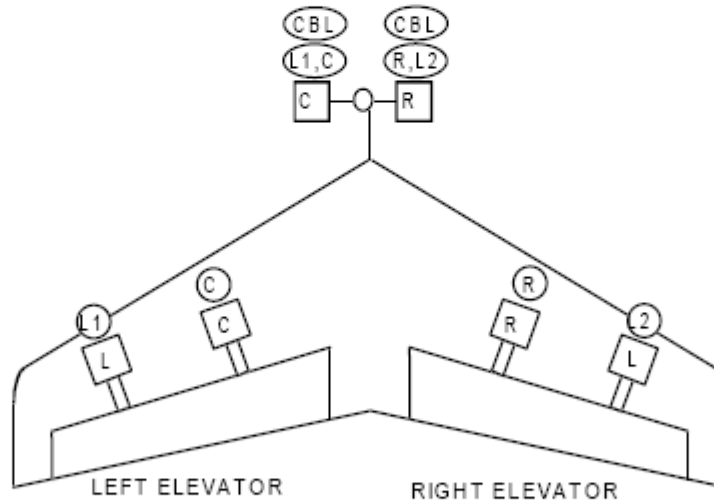
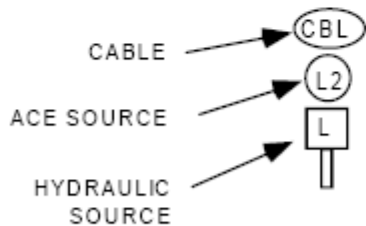

NOTE: SPOILERS 4 AND 11 ARE COMMANDED VIA CABLES FROM THE CONTROL WHEEL AND VIA THE ACES FROM THE SPEED BRAKE LEVER. THE STABILIZER IS COMMANDED VIA THE CABLES THROUGH THE AISLE STAND LEVERS ONLY AND OTHERWISE IS COMMANDED THROUGH THE ACES.

Aircraft control surface servo model

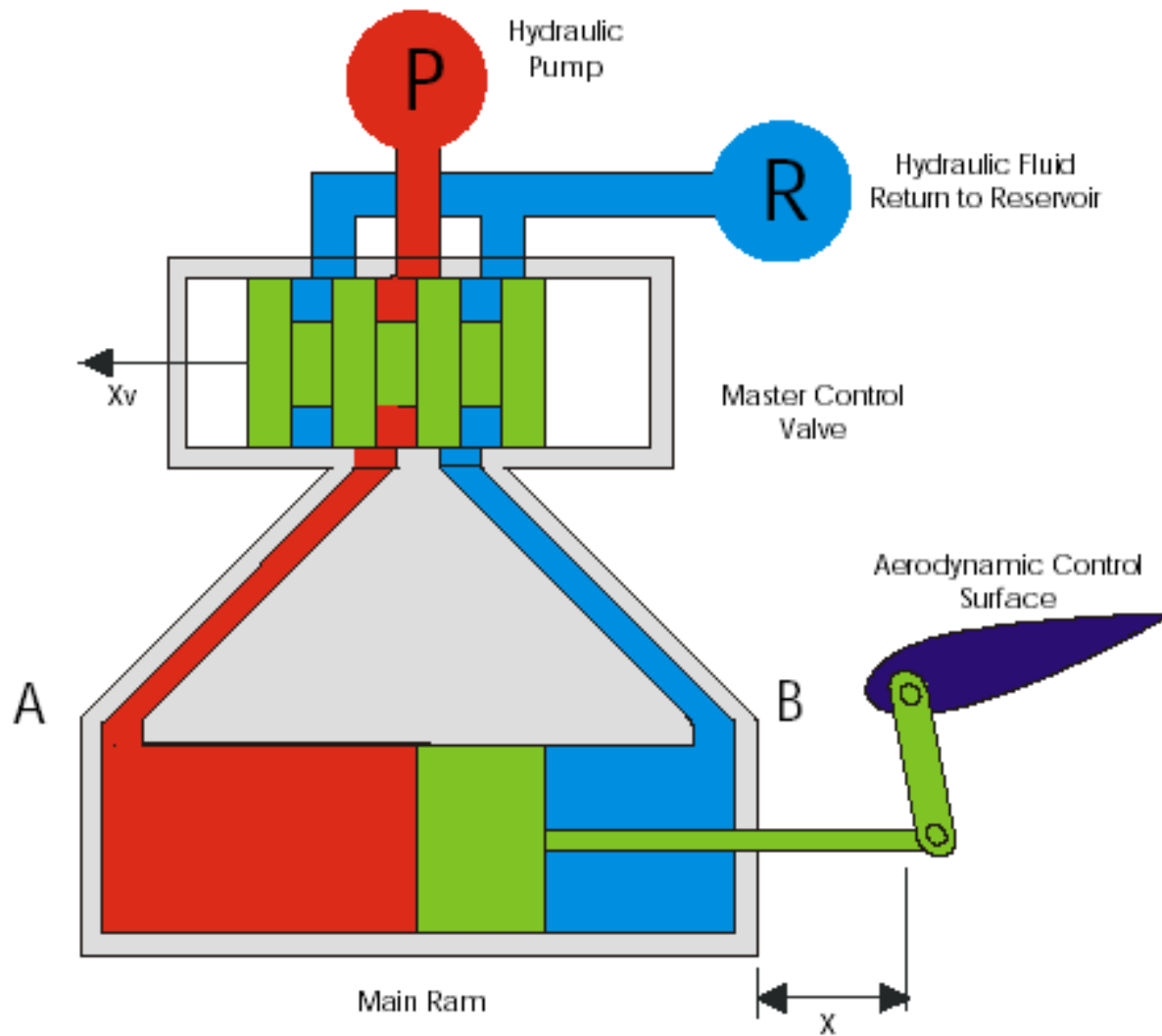

Hydraulic actuator

Aerospace Fly-by-Wire History

The first aircraft, and most current aero vehicles have mechanical linkages between the pilot and control surfaces

- WW II Era - B-17 bombing stabilization system using gyros and servo-actuators driving mechanical linkages
- 1950s - Analog autopilots using gyros and servo-actuators
- 1950s/60s - Missile control; hydraulic control augmentation systems
- 1972 - First digital FBW in research aircraft: NASA F-8 Crusader
- Late 1970s - First FBW in military aircraft: F-16 and F/A-18
- 1981 - First Space Shuttle flight, quad-redundant DFBW
- 1988 - First FBW in commercial airliner: Airbus A320, then B777
- 1999 - First fly-by-light (fiber optics) in research aircraft



Fly-by-Wire Trends

- New aerospace vehicle designs employ FBW
- Advancing high-speed digital processing and sensor technology is making digital FBW even more capable
- Complementary advances in flight simulation allow precise modeling, design, and tuning of FBW systems prior to flight
- Adaptive control systems are getting more sophisticated
 - Change vehicle response based on mission and flight regimes
 - Compensate for missing human pilot adaptation
- Build-in compensation for sub-optimal, non-linear aerodynamics
 - Stealth airframe design: Tail-less B-2 and UCAV
 - Space Planes
- Fiber optics employed for high-speed networks: Fly-by-light

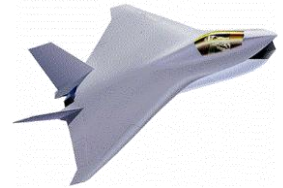

Fly-by-Wire R&D

- Survivability
 - Automatic system reconfiguration (self-repair) inspired by:
 - F-15 returned safely after losing wing in midair collision
 - DC-10 crash landed after engine failure and hydraulics loss
- Maneuvering
 - Improvements from tighter integration of control and propulsion
 - Thrust vectoring
 - Control using elastic aerostructures rather than dedicated surfaces
 - “Wing warp” (similar to the Wright Flyer)
- Human/Machine Interface
 - Sensing and prevention of pilot induced oscillation (PIO) and loss of control
- Wireless vehicles

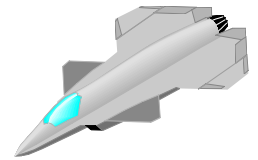

FBW Challenges: Survivability

Boeing is studying reconfigurable flight control systems with DFBW to automatically accomplish what Israeli F-15 Pilot did with hydro-mechanical systems and flying skill

System learns compensation with neural net flight control laws

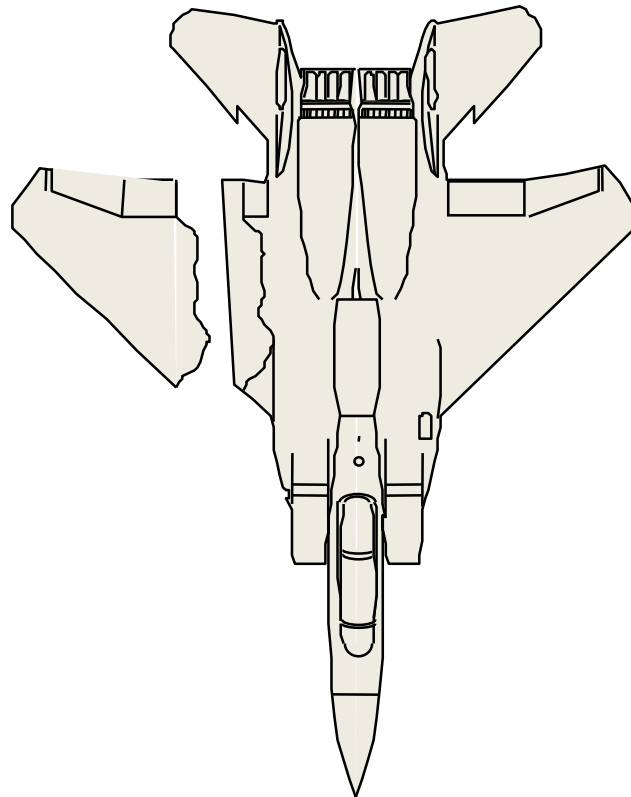

FBW Issues: Pilot Induced Oscillation

YF-22A Test Aircraft crashed after encountering PIO “porpoising” with thrust vectoring during low-altitude go-around at Edwards AFB

- Problem in matching control system response to pilot expectations

- “ I thought something was broken”

Pilot doesn’t know he is in PIO

- “ I just tried to get the nose up so I didn’t do the lawn dart trick in the runway”

Pilot switches to what he feels instead of what he sees

- Fixed with adjustments in control system rate limits and gains, ... and pilot training



- A typical FMS consists of:
 - Flight Management Computer
 - Control Display Unit
 - Visual Display (EFIS)

ACT RTE LEGS 1/11

274°	108.20	5195.6 N M	
VTU			280/12360
312°		15.7 N M	
HENER			280/15540
312°		7.3 N M	
OHIGH			280/16920
311°	117.50	48.2 N M	
FLW			280/FL274
313°		40.0 N M	
REDDE			.79/FL370

RTE DATA >

Scratchpad

INIT REF RTE CLB CRZ DES
 DIR INTC LEGS DEP ARR HOLD PROG EXEC
 MENU FIX
 PREV PAGE NEXT PAGE

A B C D E
 F G H I J
 K L M N O
 P Q R S T
 U V W X Y
 Z SP DEL / CLR

PROJECT MAGENTA

AP
 CKL
 FLT
 SET
 ENG
 CUR

NAV APPR 1/3
 HDG
 MNVR
 WIND
 APPR

DATA NAV VNAV DTO LIST PREV
 FUEL FPL PERF TIME MENU NEXT
 A B C D E F G
 H I J K L M N
 O P Q R S T
 U V W X Y Z
 ENTER

UNIVERSAL LMG-10 PRO

CONTROL DISPLAY UNIT (CDU)



HOW IT WORKS

- The Flight Management Computer is supplied with information from:
 - Navigation systems
 - Inertial reference system
 - Air data computer
 - Engine and system status
 - Aircraft specific performance database
 - Route, procedure and terrain database
 - EGPWS
 - TCAS
 - Datalink
 - Pilot inputs
- It analyzes these inputs and continually reevaluates changing parameters to provide the autopilot, flight director, and auto-throttles with commands which optimize all aspects of a flight.

FLIGHT MANAGEMENT COMPUTER INPUT/OUTPUT

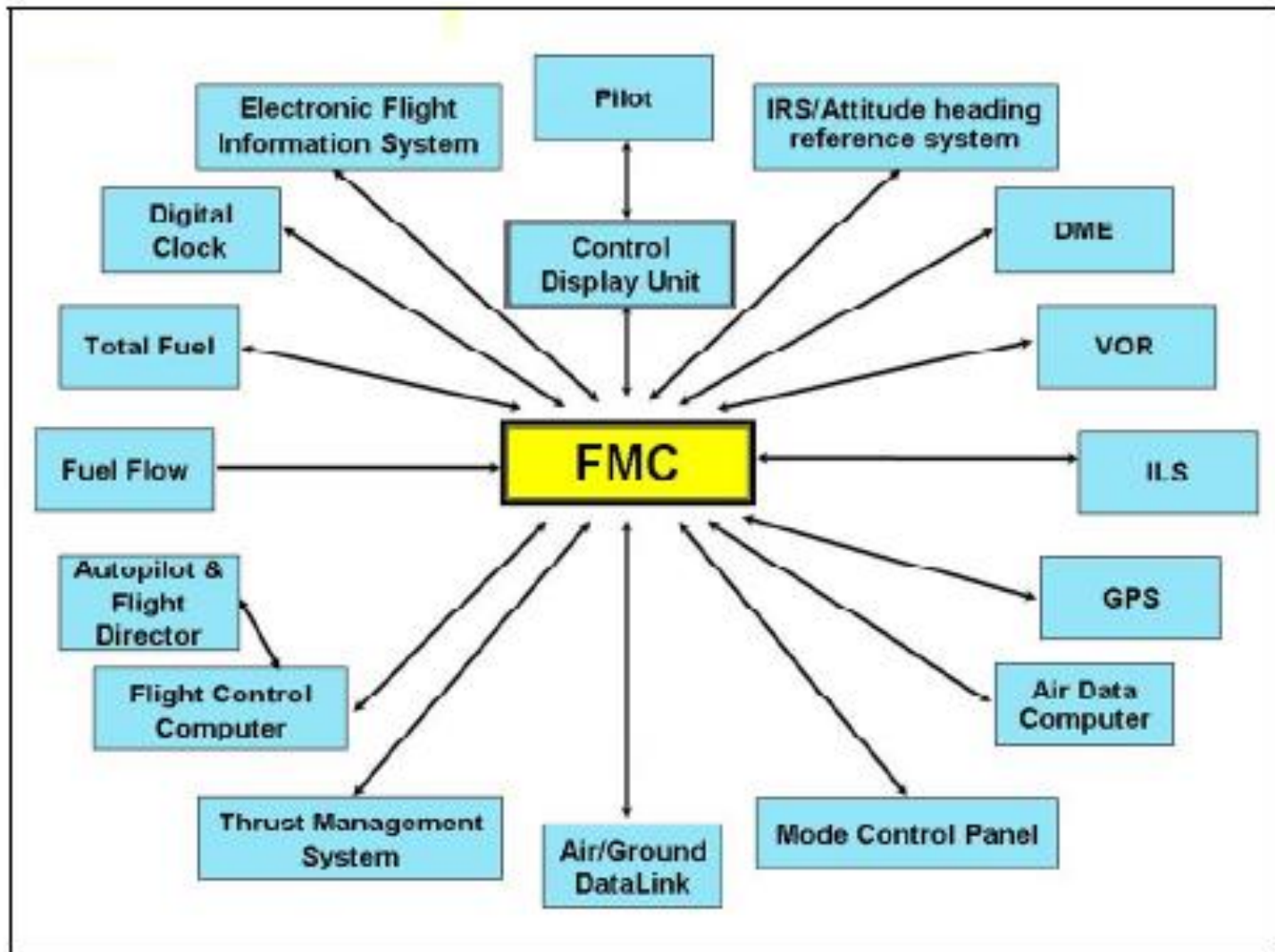

OPERATION

- The pilot must initialize and **program** the FMS with **relevant route** information.
- The **navigation** and **aircraft performance database** must be verified as current and correct. (performance must reflect the specific aircraft)
- An **initial position** must be entered. (Lat and Long)
- A GPS augmented system will take less time to initialize.
- The **required route** must be entered. This can include **specific** departure, en-route, arrival, and approach **procedures**. (manually entered or previously stored)
- Routing must be confirmed accurate and correct and any ATC changes to expected routing must be entered manually en-route.
- The pilot becomes a manager of this sophisticated system, monitoring progress and updating or changing parameters as necessary.

WHAT IT DOES

- The FMS is capable of :
 - Calculating **optimum rate of climb/descent, altitude, power setting.**
 - Controlling the aircraft to meet these optimum parameters **through autopilot and auto-throttle.**
 - **Guiding pilot controlled flight** path through a flight director, and target speed and engine setting bugs.
 - **Cross referencing multiple navigation sources** to continually update position.
 - **Automatically tuning** en-route nav aids.
 - **Alerting pilots** of systems status and malfunctions.

ADVANTAGES

- The **workload reduction** associated allows pilots more time to analyze and make decisions. (drink coffee too)
- Computer generated efficiency profiles are **more accurate**.
- **Navigation accuracy** is improved through integration and cross referencing of multiple sources.
- Improves **situational awareness**.

DISADVANTAGES

- **Reliant on pilot** input.
- **Intricacies of system** leave room for misinterpretation or erroneous data entry.
- **Loss of situational awareness.** Pilots may become so involved in operating and monitoring the system that they forget to look outside.
- **Expensive.**

Autopilot

- Basic Function of autopilot is to control the flight of the aircraft and **maintain** it on a **predetermined path** in space without any action being required by the pilot, once the pilot has selected the appropriate control mode of the autopilot.
- The autopilot can thus relieve the pilot from the fatigue and tedium of having to maintain continuous control of aircraft's flight path on a long duration flight.
- A well designed autopilot, properly integrated with FCS can achieve a **faster response** and maintain a **more precise flight path** than the pilot.
 - Eg. Auto landing
 - In Military strike aircraft autopilot in conjunction with Terrain Following guidance can provide all weather auto TF capability, enabling the ac to fly at high speed (600kts) automatically follow the terrain profile to stay below the radar horizon of enemy radars.

Autopilot Loop

- To correct a **vertical deviation** from the desired flight path, **pitch attitude** is controlled to increase or decrease the angular inclination of the flight path to the horizontal. The resulting vertical velocity component thus causes the aircraft to climb or dive so as to correct the vertical displacement from the desired flight path.
- To correct a **lateral displacement** from the desired flight path requires the **aircraft to bank** in order to turn and produce a controlled change in heading so as to correct the error.
- The pitch attitude control loop and the heading control loop, with its inner loop commanding the aircraft bank angle, are fundamental inner loops in various autopilot modes.
- The **outer autopilot loop** is thus an essentially a **slower**, longer period control loop compared with the **inner flight control loops** which are **faster**, shorter period loops.

Automatic Flight Control System

- Flight Director
- Autopilot
- Thrust Director
- Auto-Throttle
- Provides functions necessary for automatic control.
- The system consists of:
 - Mode Control Panel (MCP)
 - **THREE** Autopilot Flight Director Computers (AFDCs)
 - Flight Director
 - Back drive Control Actuators (BACs) ... etc.
- AFDS **does not** have direct control of Primary flight Control Surfaces.
- The Flow is:

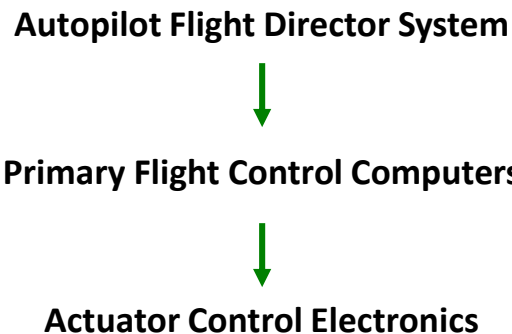

Autopilot Flight Director System (777)

Triplex system provides multichannel cruise autopilot and flight director control functions for

- **speed** selection,
- **altitude** modes,
- **heading**/track modes,
- **vertical speed/flight path** angle modes,
- vertical/lateral **flight management** control selection,
- fully **automatic landing** and go-around modes.

The autopilot is an interface between the AFCS-FD and flight controls for roll and pitch commands.

Yaw dampers provide turn coordination and yaw damping.

The autopilot is integrated with the flight director to automatically **control and direct the flight path** of the aircraft.

When engaged, the autopilot controls the aircraft's pitch and roll axes in accordance with the coupled flight director commands.

Fly-by-wire **backdrive** system: wheel, column and pedal feedback for the 777 fly-by-wire system under autopilot control.

Autopilot Engagement Criteria

The autopilot can be engaged provided the following conditions exist:

- at least one **yaw damper is engaged** (normally, both YDs are engaged)
- AP DISC switch-bar on the FCP is in the normal position
- **no faults detected** in the active Flight Control Computers (FCCs)
- **no significant instability exists**, including:
 - adverse pitch / roll / yaw rates
 - G-loads exceeding predetermined values
 - adverse pitch / roll attitudes exceeding predetermined values

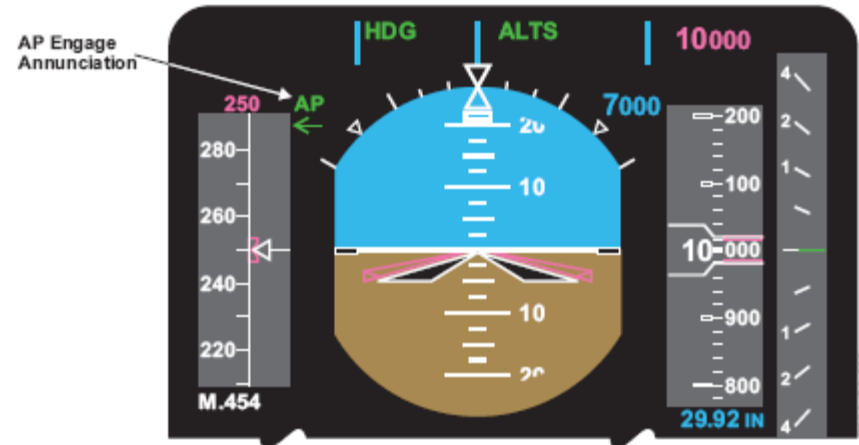

Monitored Disengagement

The FCCs continually monitor aircraft sensors, servo data, the automatic pitch trim

system and internal parameters for faults. The autopilot will automatically disengage if

any of the following conditions occur:

- internal monitors detect a **failure in any axis**
- any **power source** to the **FCCs** is lost
- **loss** of either **inertial reference system** (IRS) system input
- dual **yaw damper** failure
- aircraft is at an **excessive attitude** (pitch angle beyond +25° or -17°, roll angle beyond $\pm 45^\circ$), or
- either **stick shaker** activates

Flight Directors (FDs) Description

The flight directors (FDs) are the **visual representation** of the commands generated by the flight control computers.

The flight directors provide **pitch and roll guidance** by means of inverted V-shaped command bars on the attitude director indicator (ADI) of the PFD. The pilot can **manually fly** the aircraft by following the command bar guidance cues. When autopilot is engaged, the FCCs issue steering commands to the aileron and elevator servos according to the flight director guidance instructions.

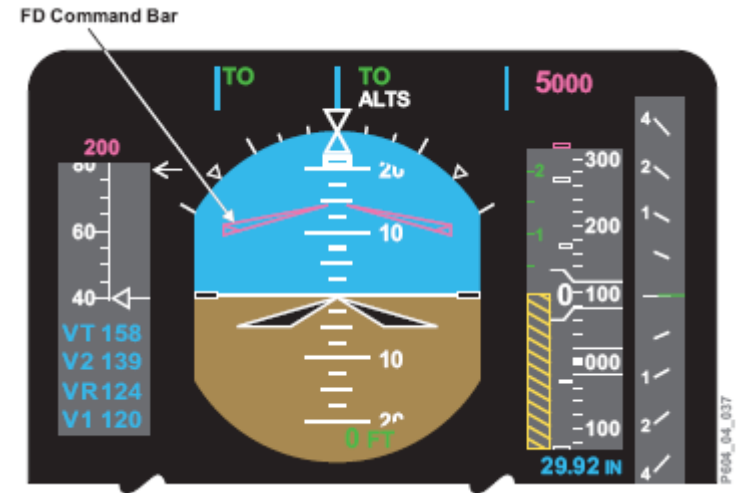

Flight Director Lateral Modes

There are eight flight director lateral modes (bold letters refer to the Flight Control Panel button selections):

- **Roll** (default) - maintain a reference bank angle (if larger than 5deg) or roll back to 0
- **Heading Select (HDG)** - capture and maintain the selected heading (heading knob)
- **Half Bank (1/2 BANK)** - reduces the roll limit to half the normal value of active mode
- **Navigation; FMS, VOR, LOC (NAV)** - capture and track the active navigation source
 - VOR capture and track the selected VOR radial,
 - LOC capture and track the front course localizer from the active navigation source,
 - FMS capture and track the desired track to the “TO” waypoint)
- **Approach; FMS – non precision or RNAV, VOR, LOC- ILS based (APPR)**
- **Back Course (B/C)**
- **Takeoff** – autopilot is disengaged
- **Go-Around** - establish a rate of climb

Lateral modes are armed or activated by pushbuttons on the flight control panel or on the thrust levers.

Flight Director Vertical Modes

There are nine vertical flight director modes (bold letters refer to the Flight Control Panel button selections):

- **Pitch** (default) - maintain the aircraft's pitch angle reference
- **Altitude** Preselect - generate commands to capture and level off at the preselected altitude
- **Altitude Hold (ALT)** - maintain the pressure altitude at the time of selection
- **Vertical Speed (VS)** - maintain a vertical speed reference value
- **Flight Level Change (FLC)** - 100 ft/min vertical speed toward the preselected altitude
- **Takeoff** – autopilot off, generates a 14-degree pitchup command
- **Go-Around** - generates a 10-degree pitch-up command
- **Glideslope** - generates commands to capture and track the glideslope of an ILS approach
- **FMS Vertical Navigation (VNAV)** - allows the FMS to provide vertical steering commands to the flight director to ensure the vertical flight profile of the active flight plan

Vertical modes are armed or activated by the FCP pushbuttons, a pitch wheel on the Flight Control Panel, or by TOGA switches on the thrust levers. In general, disabling the active vertical mode is accomplished by reselecting the active FCP pushbutton or by selecting another vertical mode.

5. PFCS/SFCS

The Flight Control System description is decomposed in:

- **Primary Flight Control System**, which allows controlling the trajectory of the airplane

Primary Flight Control System include:

- Ailerons,
- Tail Horizontal Stabilizer,
- Elevators,
- Rudder,
- Spoilers.

- **Secondary Flight Control System**, which allows aerodynamic configuration optimization

The secondary Flight Controls System include:

- Slats System,
- Flaps System,
- Airbrakes System (including airbrakes and spoilers panels).

The 777 is certified to be dispatched on a revenue flight, per the Minimum Equipment List (MEL), with two computing lanes out of the nine total (as long as they are not within the same PFC channel) for 10 days and for a single day with one total PFC channel inoperative.



Primary flight control



Secondary flight control



Primary and Secondary flight control

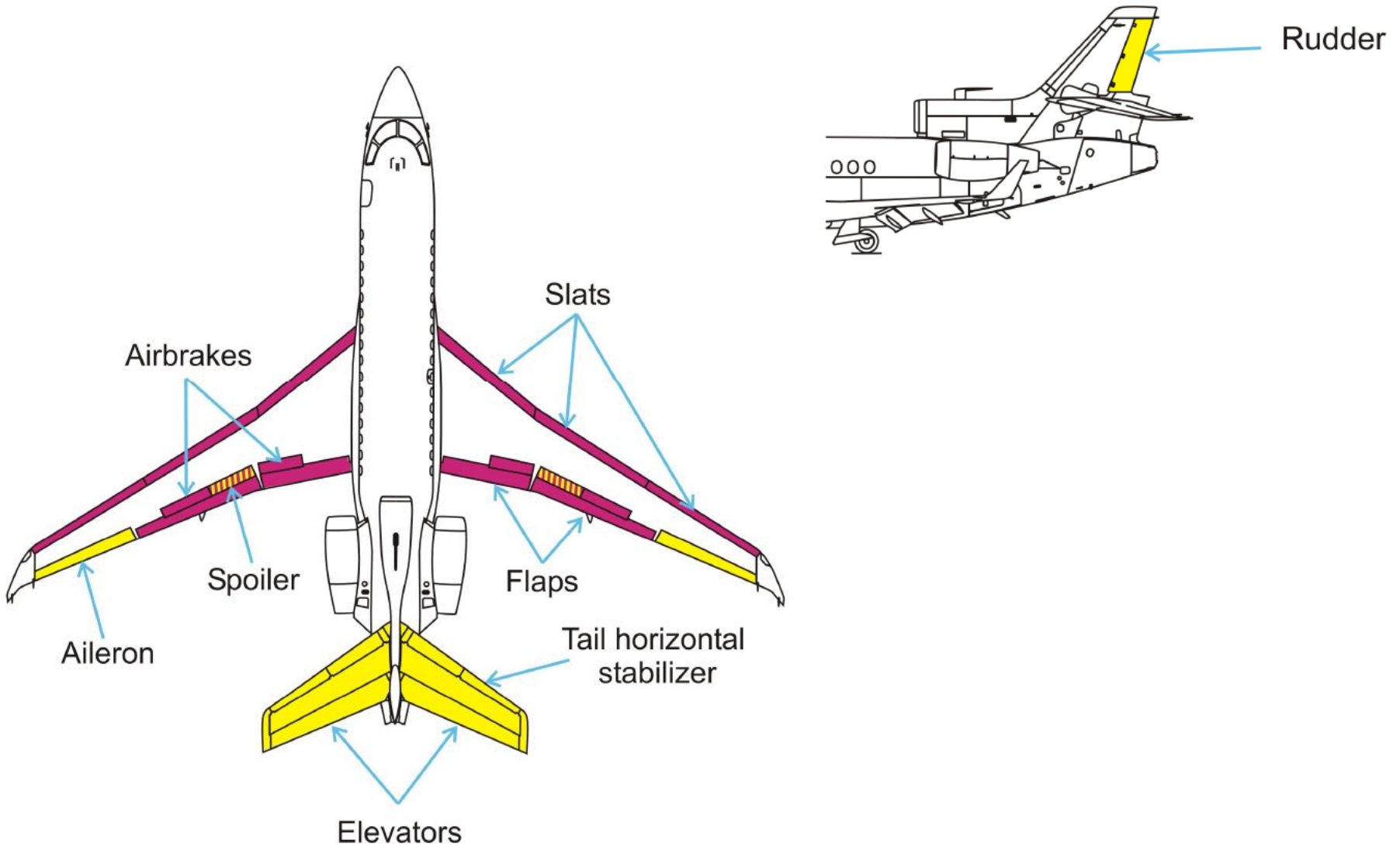

Boeing 777 Fly-By-Wire Flight Control System

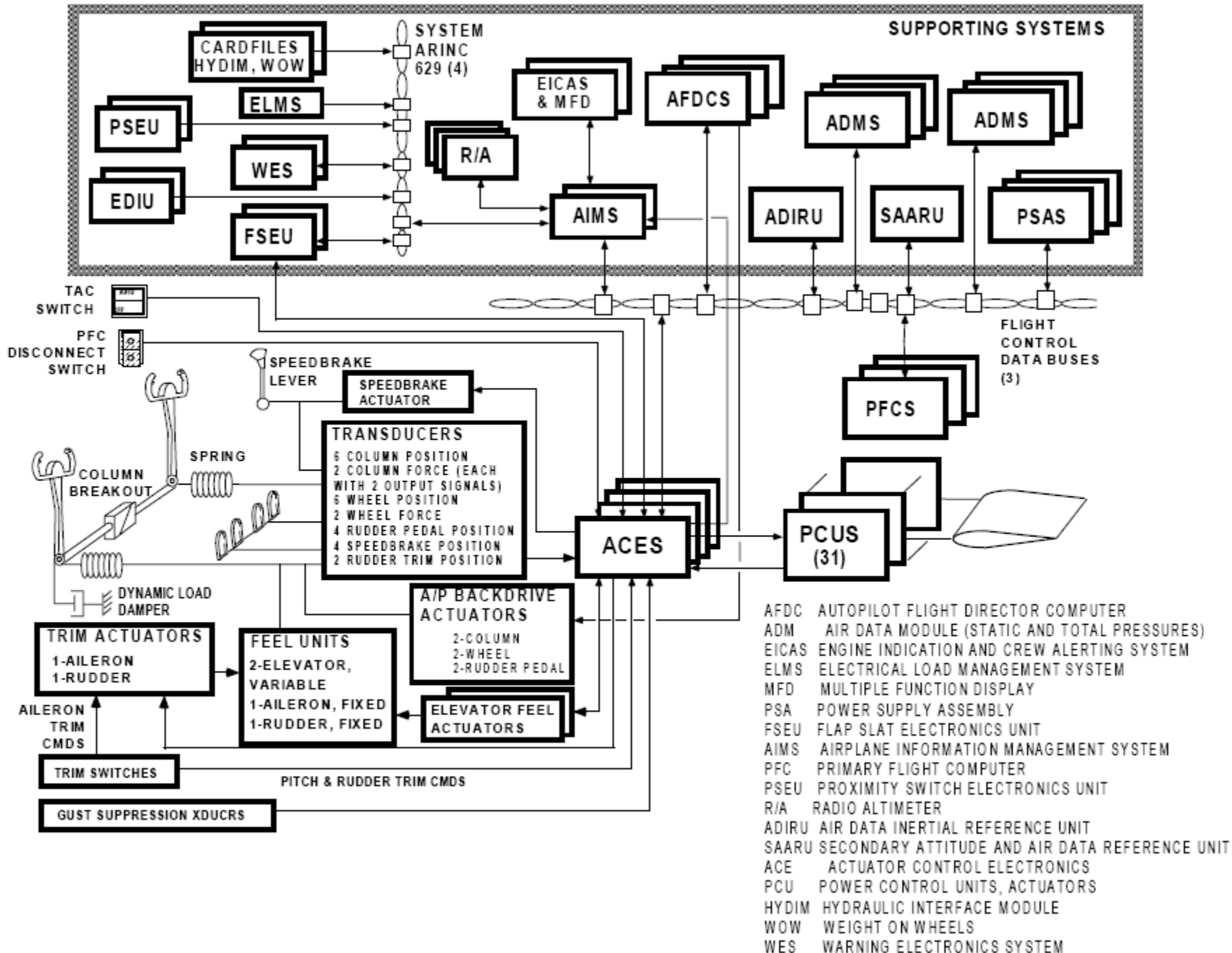

FBW Databus (777)

- There are 3 lanes of ARINC 629 buses
 - Used to ensure a complete set of redundant resources is available to each lane.
 - Minimize complexity of input interface
 - Each bus is physically & electrically separated, labeled Left, Center, Right
- ARINC 629 Terminal Controller
 - Each word is encoded with CRC
 - Employs dedicated hardware for error detection and correction

FBW Architecture Overview (B777)

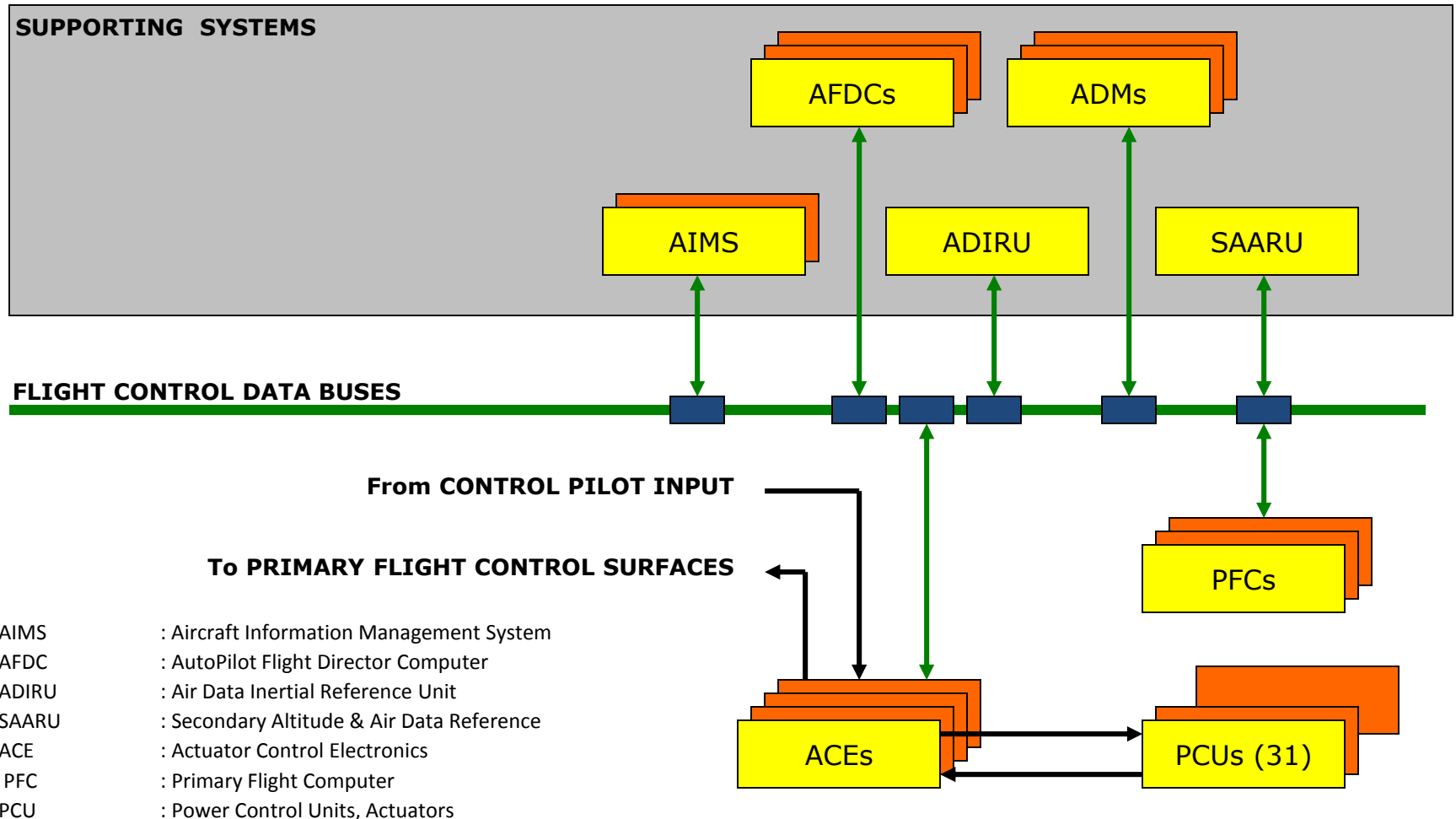

Role of Primary Flight Computer (FCC)

Receive Inertial Data from

- Air Data Inertial Reference System (ADIRS)
- Secondary Altitude and Air Data Reference Unit (SAARU)
- Actuator Control Electronics (ACE)
- Compute Control – Surface position commands depending upon the data received.
- Transmit position commands back to the Actuator Control Electronics via the DATAC (commonly called the ARINC 629) buses.

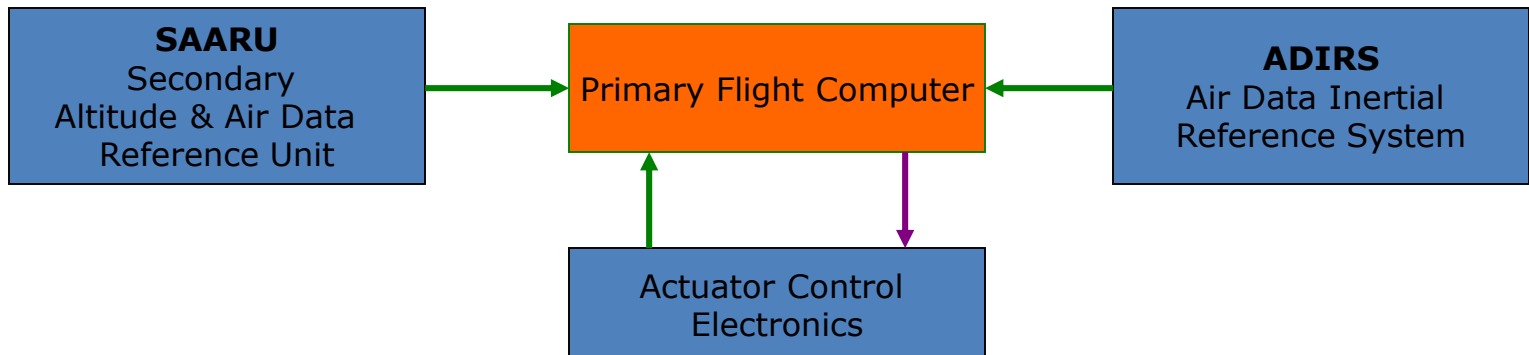

PFCS (Falcon 7X)

The Primary Flight Control System (PFCS) architecture is based on six main functionalities:

- **Data collection:**

- From sensors (IRS, AHRS, RA, ADS,...),
- From pilots controls,
- From the Flight Director if the AutoPilot is engaged,

- **Calculation of control surfaces** commands by the main and secondary Flight Control Computers,

- **Selection of Flight Control Computer** for control surface commands and transmission of commands to actuators,

- **Actuation of flight control surfaces** by the actuators,

- **Monitoring of actuators,**

- **Data exchanges with avionics.**

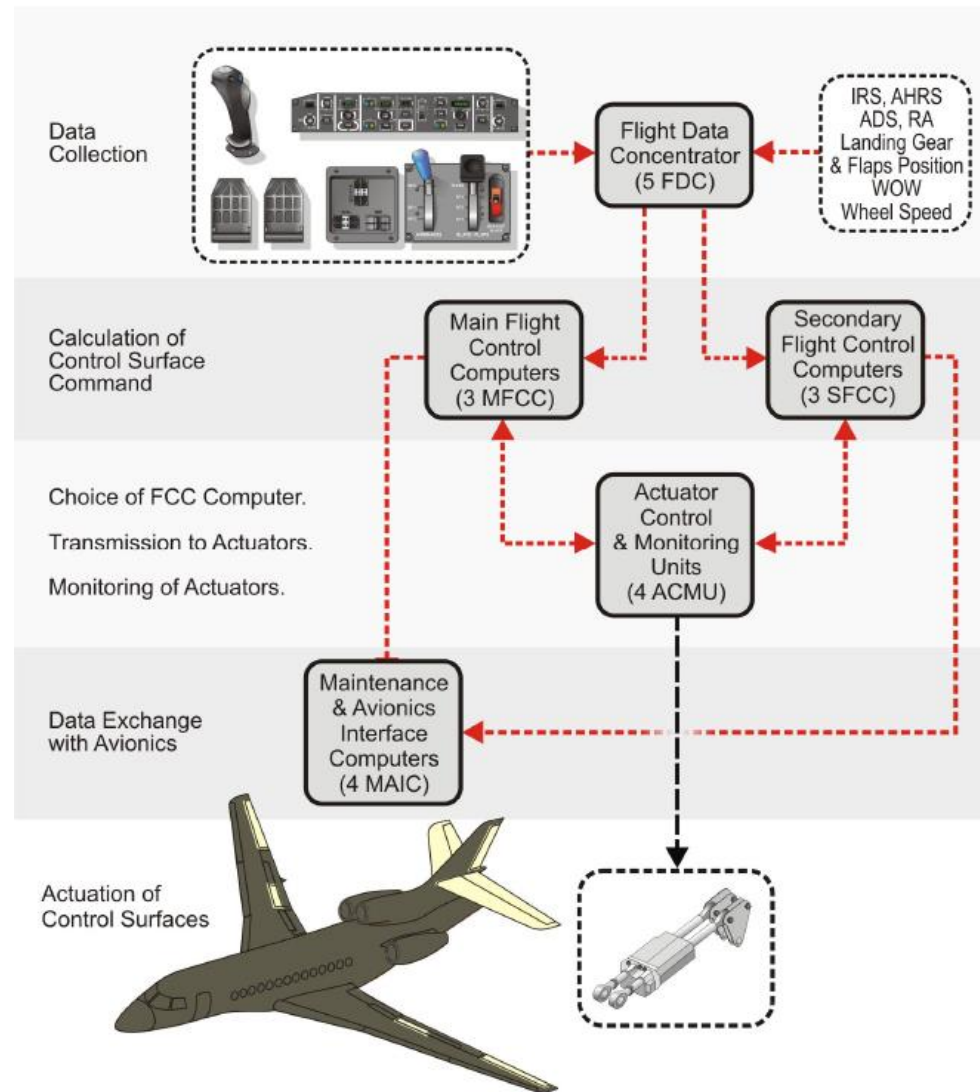

Autotrim

Autotrim on the pitch axis

In flight (above 50 ft RA): pitch autotrim maintains, stick free, a zero flight path angle variation.

Autotrim on the roll axis

Roll autotrim functions aim at:

- Providing a compensation for large or small asymmetries (fuel unbalance or failure of Ailerons / Spoilers / Airbrakes)

The roll autotrim maintains:

- Stick free: with the bank angle within $\pm 35^\circ$, the roll rate is maintained to zero.

Autotrim on the yaw axis

Yaw autotrim functions aim at:

- Compensating small asymmetries (fuel unbalance for example)
- Providing a partial compensation of lateral engine failure.

The yaw autotrim maintains:

- Pedal free: a zero body axis lateral acceleration.

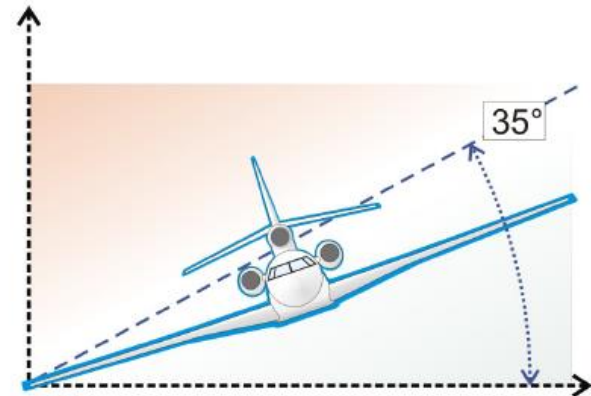

Protections

Speed and stall

The PFCS provides overspeed protection as well as stall protection even when the AutoPilot (AP) is not engaged.

Excessive attitude protection

The excessive attitude protection function aims at preventing the airplane from exceeding pitch angle:

- 25° pitch angle for speed below 100 kt to 35° pitch angle for speed above 250 kt with sidestick on its aft stop,
- -18° pitch angle for speed below 100 kt down to -28° pitch angle for speed above 250 kt with sidestick on the forward stop.

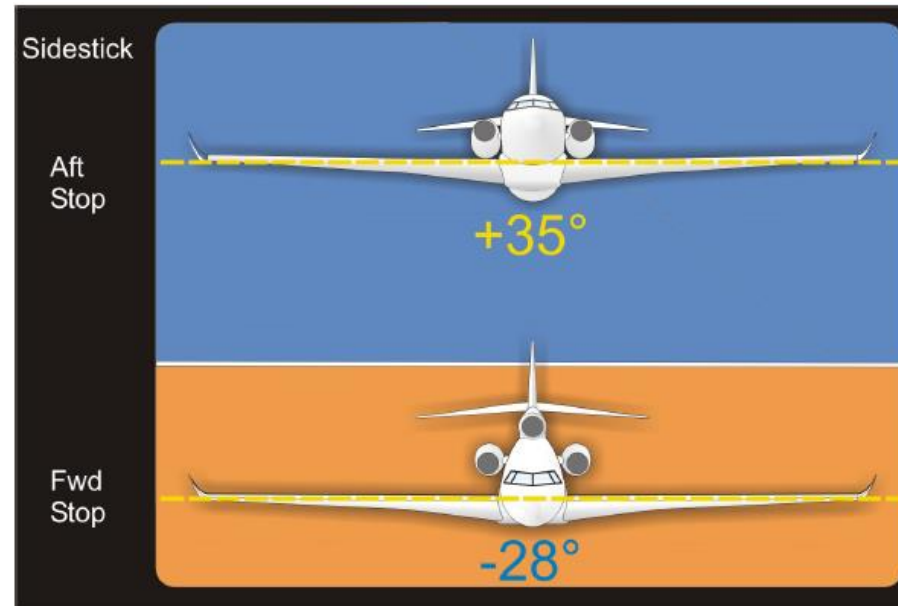

Functions in Modes (B777)

CONTROL MODE	PITCH	ROLL	YAW
NORMAL CONTROL	CONTROL C* Maneuver Cmd with Speed Feedback Manual Trim for Speed Variable Feel ENVELOPE PROTECTION Stall Overspeed AUTOPILOT Backdrive	CONTROL Surface Cmds Manual Trim Fixed Feel ENVELOPE PROTECTION Bank Angle AUTOPILOT Backdrive	CONTROL Surface Cmd Ratio Changer Wheel/Rudder Cross Tie Manual Trim Yaw Damping Fixed Feel Gust Suppression ENVELOPE PROTECTION Thrust Asymmetry Compensation AUTOPILOT Backdrive
SECONDARY CONTROL	CONTROL Surface Cmd (Augmented) Flaps Up/Down Gain Direct Stabilizer Trim Flaps Up/Down Feel	CONTROL Surface Cmd Manual Trim Fixed Feel	CONTROL Surface Cmds, Flaps Up/Down Gain PCU Pressure Reducer Manual Trim Fixed Feel Yaw Rate Damper (If Available)
DIRECT CONTROL	CONTROL Surface Cmd (Augmented) Flaps Up/Down Gain Direct Stabilizer Trim Flaps Up/Down Feel	CONTROL Surface Cmd Manual Trim Fixed Feel	CONTROL Surface Cmds, Flaps Up/Down Gain PCU Pressure Reducer Manual Trim Fixed Feel

- The FCS may be reconfigured dynamically to cope with a loss of system resources.
- Dynamic reconfiguration involves switching to alternative control software while maintaining system availability.
- Three operational modes are supported
 - Normal - control plus reduction of workload;
 - Alternate - minimal computer-mediated control;
 - Direct - no computer-mediation of pilot commands.
- At least 2 failures must occur before normal operation is lost.

LONGITUDINAL CONTROL IN NORMAL, ALTERNATE AND DIRECT LAWS

For longitudinal control, the following control surfaces are used:

- Primarily Elevators for the short term actions or when the Horizontal Stabilizer (HS) reaches maximum position for trims,
- Horizontal Stabilizer for long term actions (trims),
- Ailerons and Spoilers for Trimmable HS load alleviation.

Load alleviation consists in limiting elevators deflection to limit loads on the THS. This function, active above 300 kt, uses the ailerons above 1.3 g and the spoilers above 1.6 g.

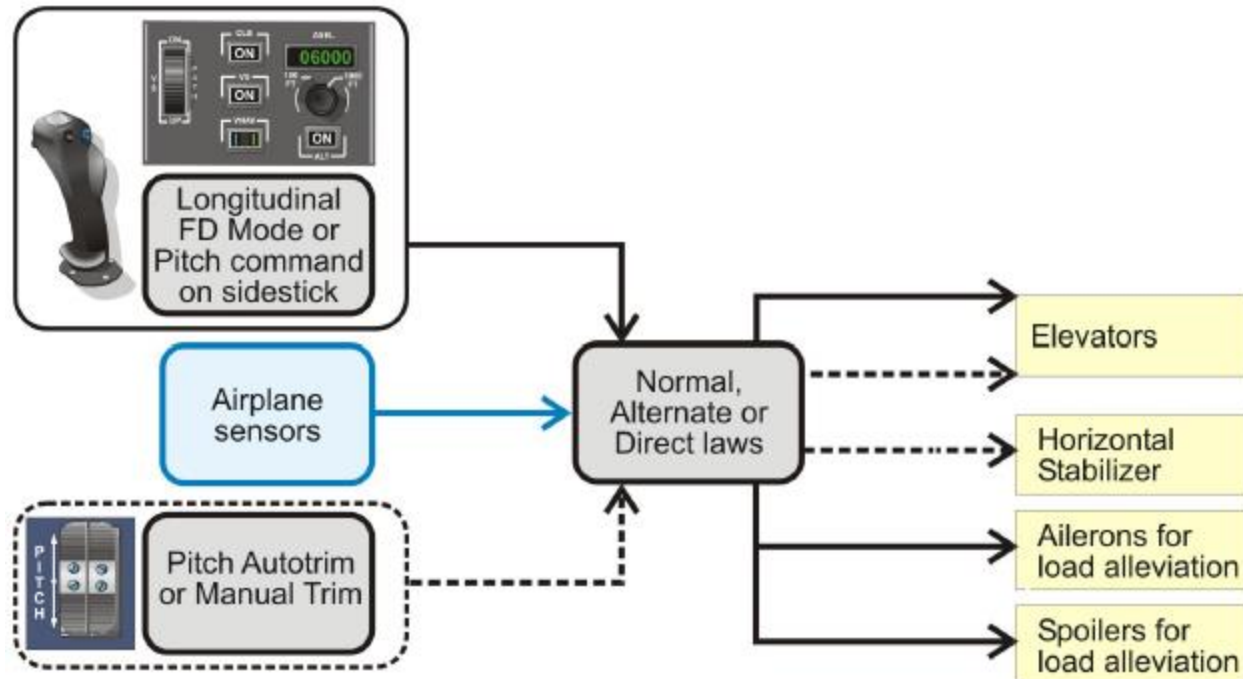

LATERAL CONTROL IN NORMAL, ALTERNATE AND DIRECT LAWS

For lateral control, the following control surfaces are used:

- primarily Ailerons,
- Spoilers,
- Rudder for turn coordination.

Pitch autotrim will be activated when available to maintain flight path during roll maneuvers.

In this case, no pilot pitch input is required to maintain the flight path during turns.

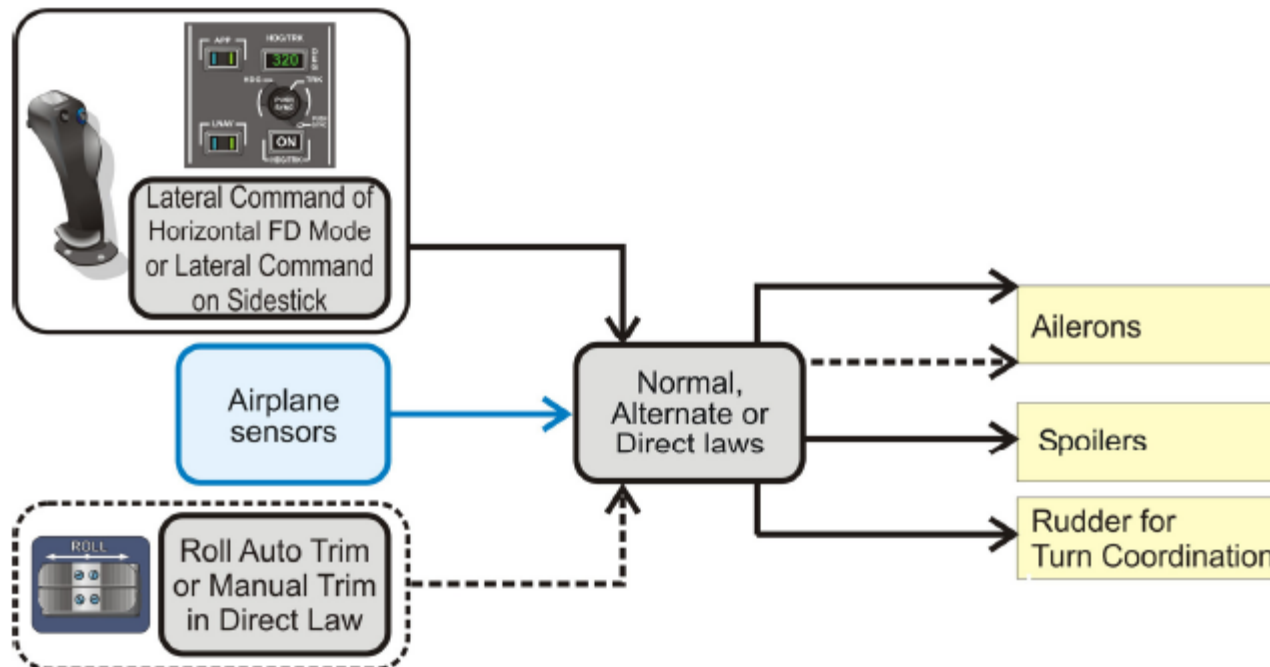

YAW CONTROL IN NORMAL, ALTERNATE AND DIRECT LAWS

In flight

For yaw control in flight, the following control surfaces are used:

- Rudder,
- Ailerons.

Commands for longitudinal control are received

- From the pedals,
- From the yaw auto or manual trims when available.

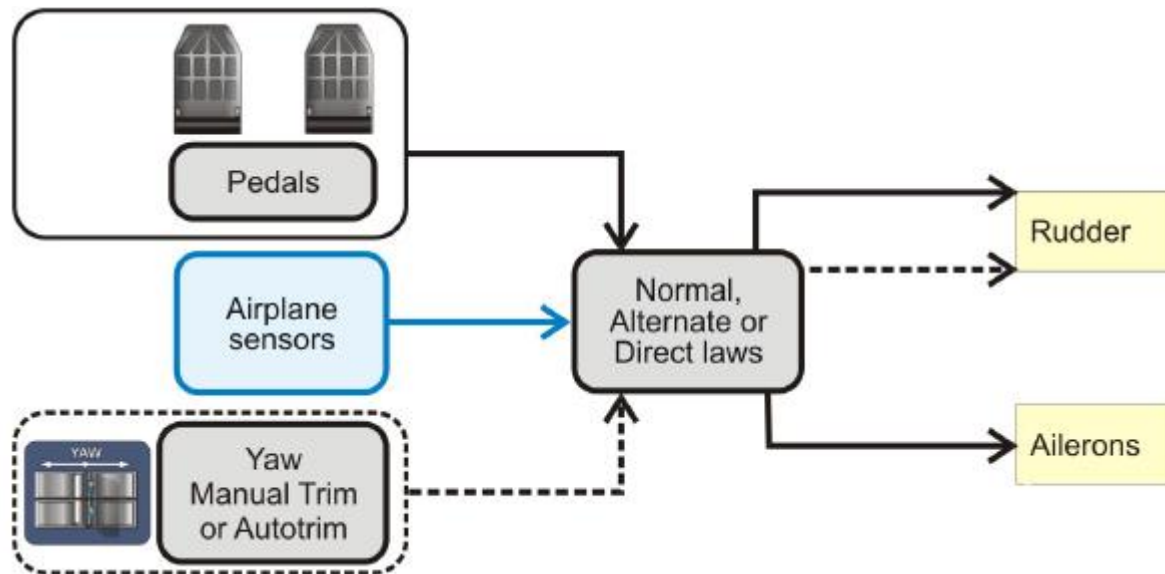

AutoPilot engaged (Falcon 7X)

When the AutoPilot is (AP) engaged:

- **Sidesticks** are restrained in **neutral position** by means of an electromagnetic devices adding a supplementary force threshold to disengage,
- Sidestick **commands are inhibited** as long as the effort exerted on the sidestick are **below** this **force threshold**,
- The **AutoPilot is disengaged** as soon as the **deflection** of the stick on one or both axis **exceeds** the value corresponding to the force **threshold** or other disengagement: then the force feedback law return to normal mode.

B777 ACE:

- primarily an **analog device**
- There are **four ACEs** - roughly correspond to the left, center, and right hydraulic systems
- ACE is to interface with the **pilot control transducers** and to control the **Primary Flight Control System** actuation with analog servo loops
- All ACEs **receive data from all 3 ARINC629 Databuses**
- They send **data back** to the **PFC** and to the **pilot feel system**
- Send pressure data about **force fight compensation**
- Each PFC channel then does a **mid-value select** on the three commands, and that value (whether it was the one calculated by itself or by one of the other PFC channels) is then **output to the ACEs** for the individual actuator commands. In this manner, it is assured that each ACE receives identical commands from each of the PFC channels.
- At any given time, at least one of the remaining three **ACEs is monitoring the operational ACE** for faults or incorrect output commands.

ACE

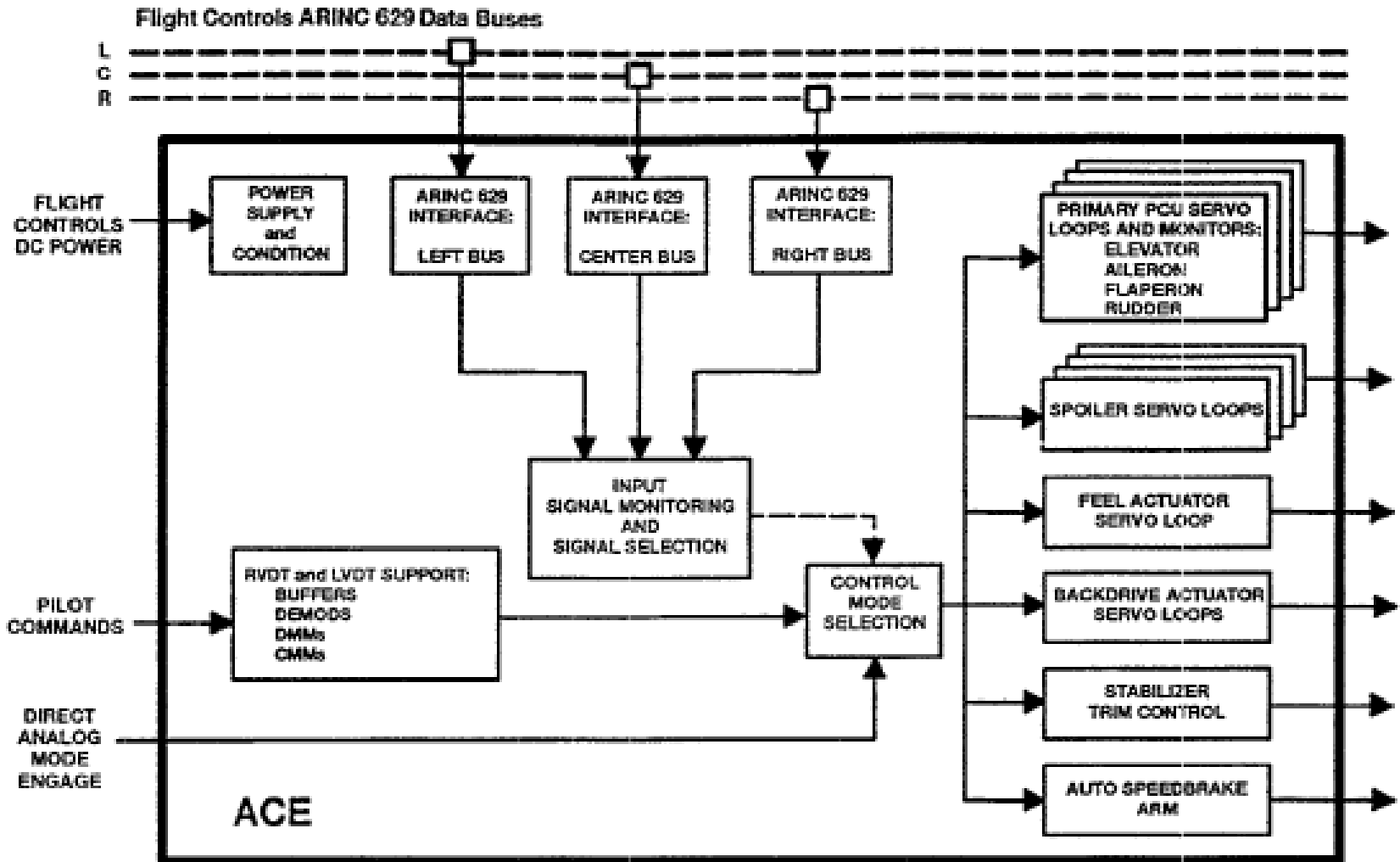

ACEs

- There is fault tolerance in the ACE architecture. The flight control **functions are distributed among the four ACEs** such that a total failure of a single ACE will leave the major functionality of the system intact. A single actuator on several of the primary control surfaces may become inoperative due to this failure, and a certain number of spoiler symmetrical panel pairs will be lost. However, the pilot flying the airplane will notice little or no difference in handling characteristics with this failure. A **total ACE failure** of this nature will have much the same impact to the Primary Flight Control System as that of a **hydraulic system failure**.

Aircraft control surface servo model

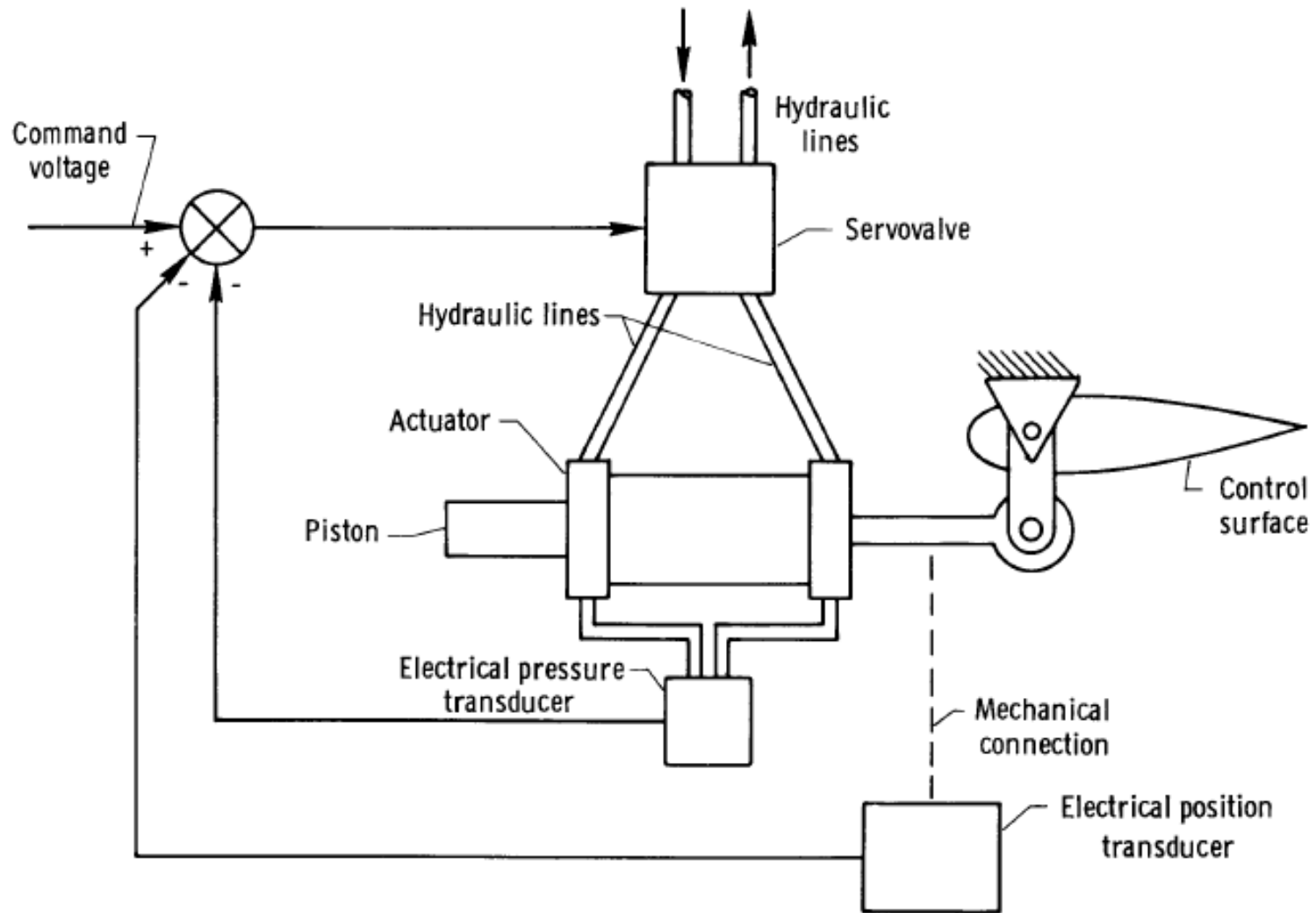

Safety & Integrity:

- Typical Military requirements
 - probability of catastrophic fault $< 1e-07$ per flight hr.
- Typical Commercial requirements
 - probability of catastrophic fault $< 1e-09$ per flight hr.

For single channel MTBF = 3,000 hrs
failure probability is $0.33e-03$ per flight hr

Fly-by-Wire Design Philosophy

- Must meet extreme high levels of **Functional Integrity & Availability**.
- Safety Considerations:
 - Common mode / Common Area Faults
 - Separation of FBW components
 - FBW Functional Separation
 - Dissimilarity
 - FBW Effect on Structure.
- Usage of Hardware Redundancy for all hardware resources, namely.
 - Computing Systems
 - Airplane Electrical Power
 - Hydraulic Power
 - Communication Paths.

Shuttle Redundant Architecture

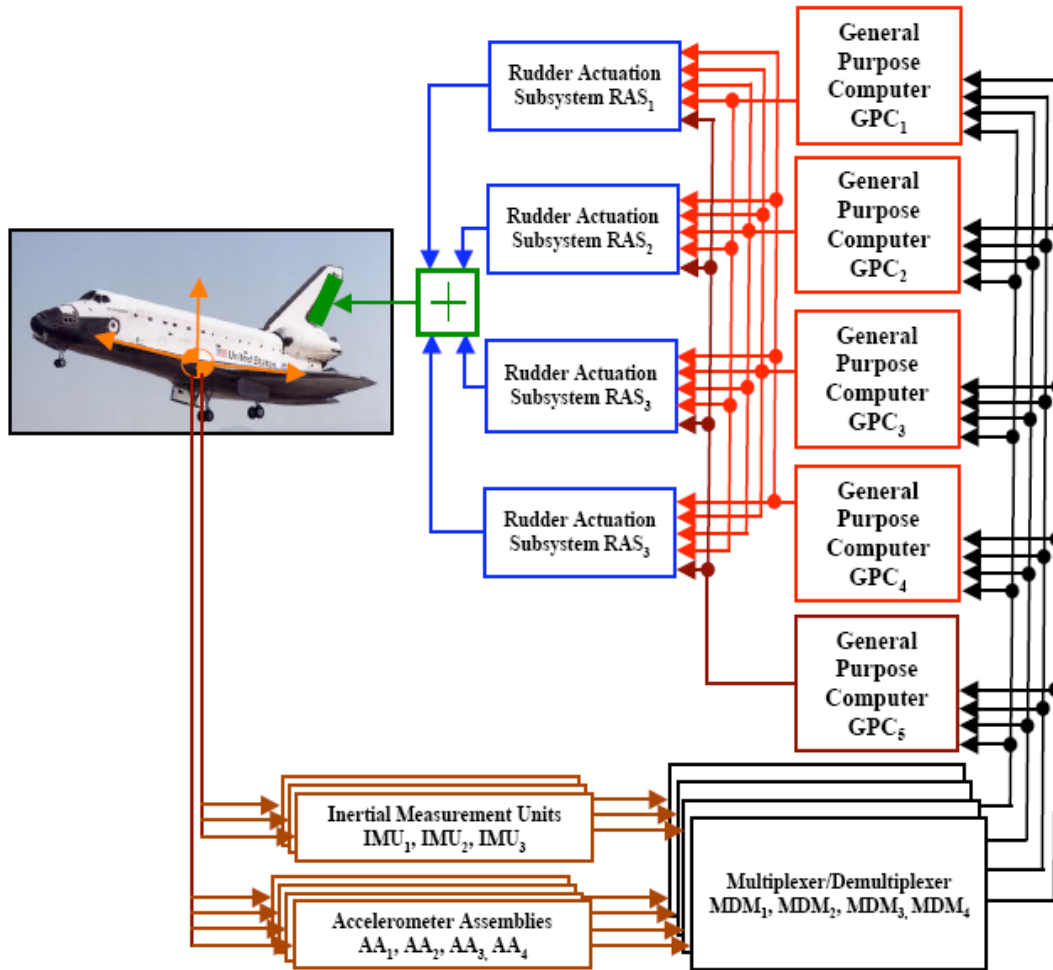

Duplex System

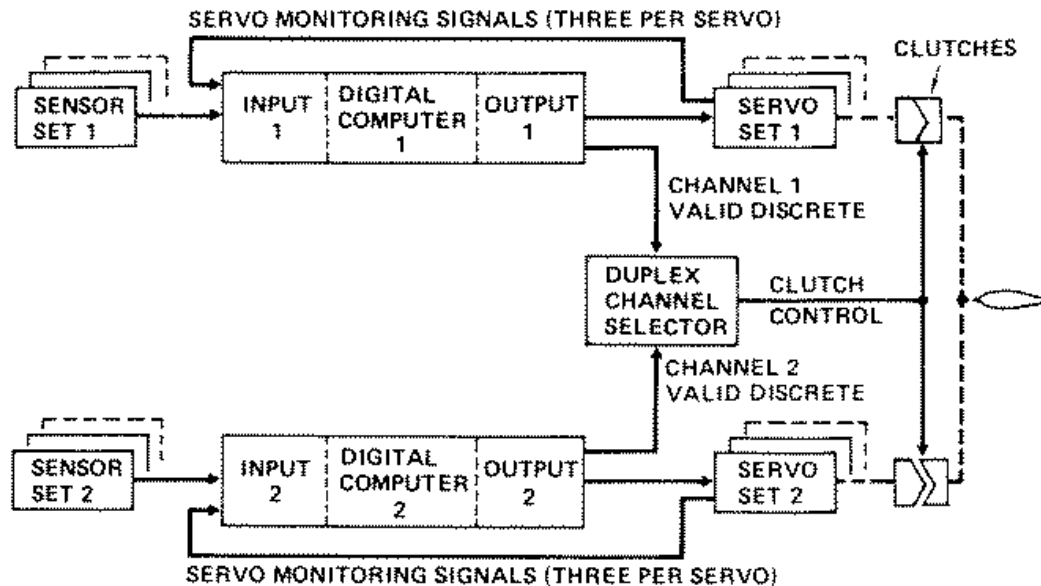

Fail-Passive flight control system.

A flight control system is fail-passive if, in the event of a failure, there is no significant out-of-trim condition or deviation of flight path or attitude but the landing is not completed automatically. For a fail-passive automatic flight control system the pilot assumes control of the airplane after a failure.

Triplex System

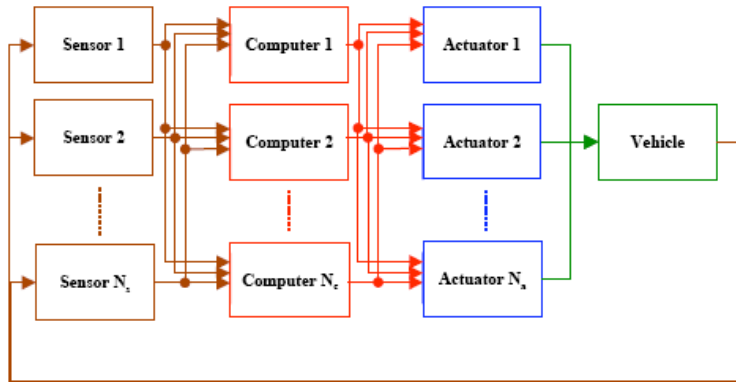

Cross strapped architecture

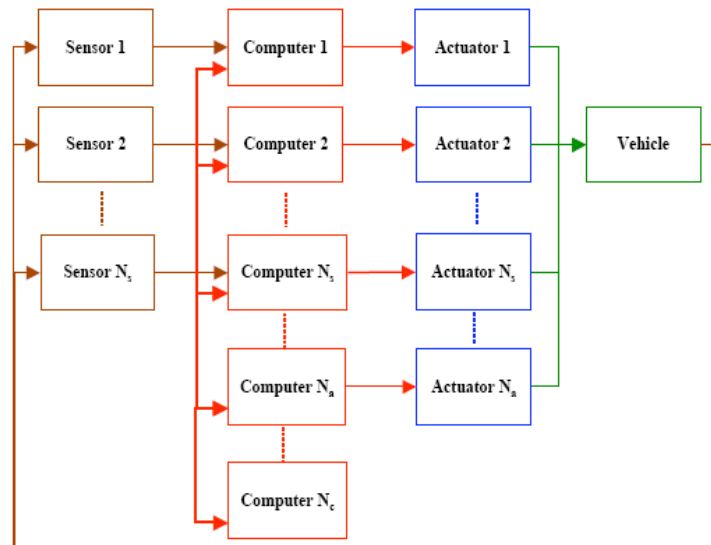

Channelized architecture with computers cross-talk

Fail-Operational flight control system.

A flight control system is fail-operational if, in the event of a failure below alert height, the approach, flare and landing, can be completed automatically. In the event of a failure, the automatic landing system will operate as a fail-passive system.

777 FBW PFC

- Each PFC is made up of 3 internal lanes

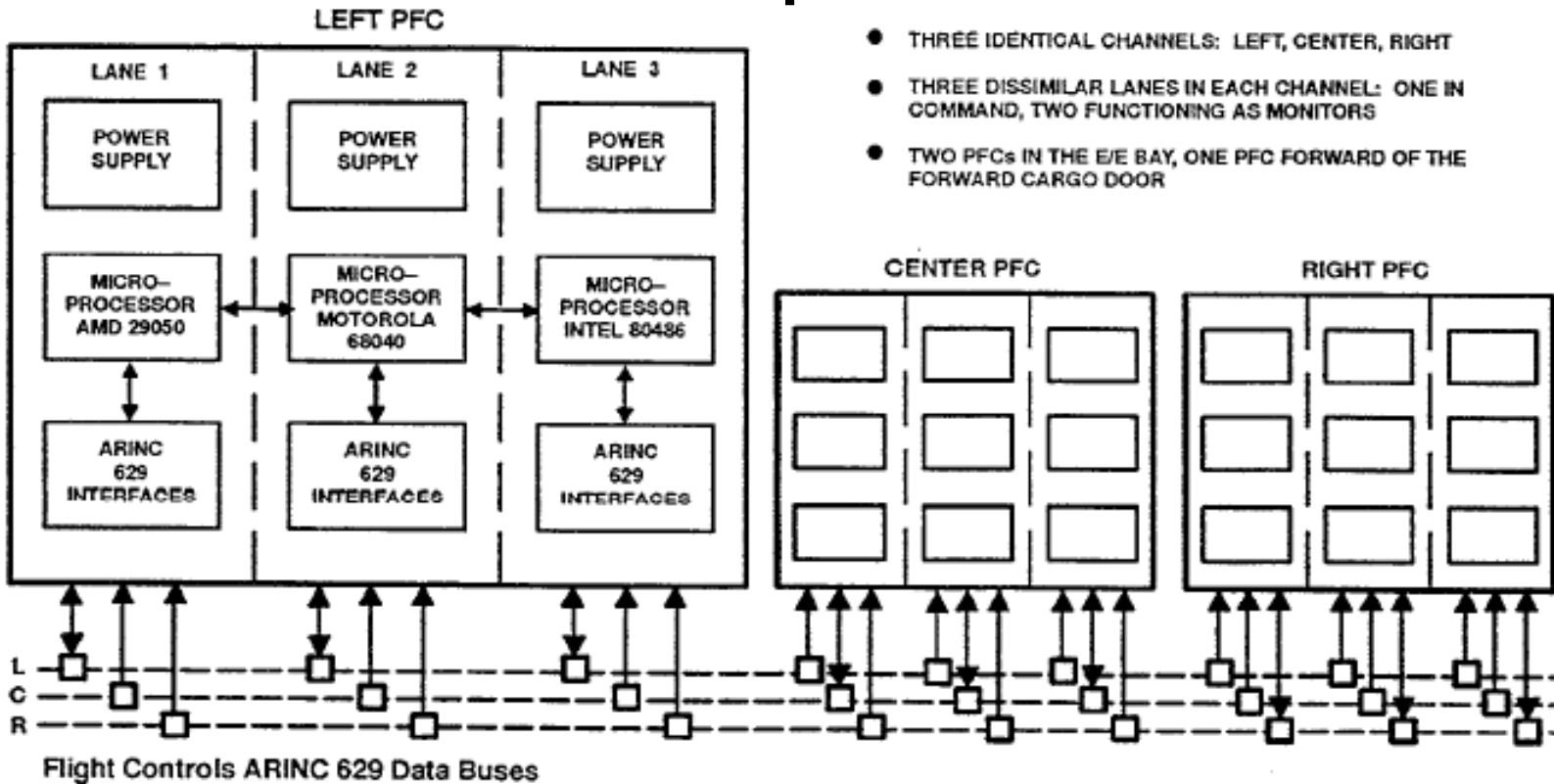

Each PFC receives data from all 3 databuses, but transmit only on 1 databus. This is meant to prevent a failed lane from contaminating good lane with erroneous data, or worst, prevent masquerading error.

777 PFC Command Lanes

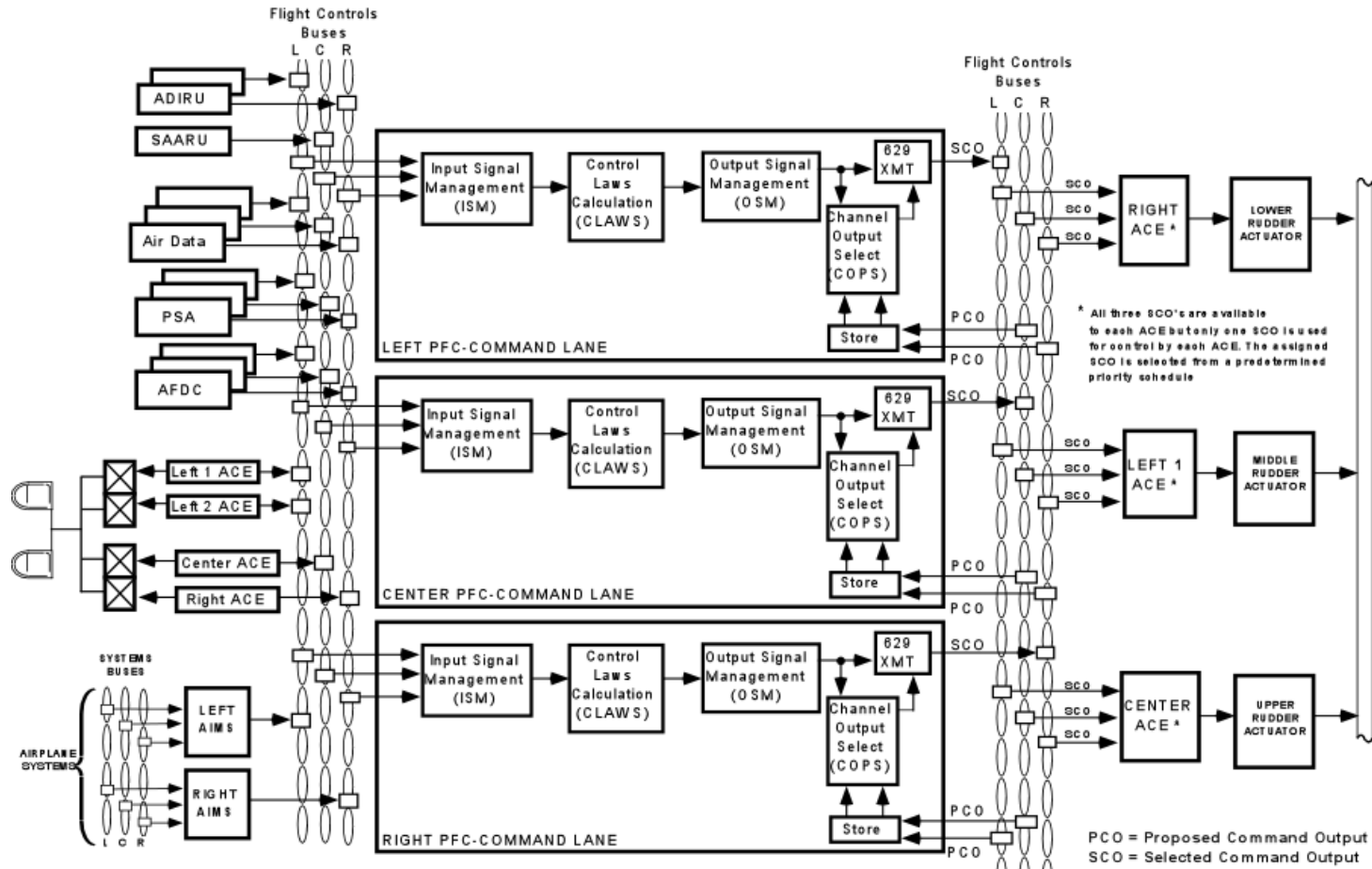

PFC Redundancy Management

- Each PFC Lane can operate in two modes:
 - Command Mode
 - Monitor Mode
- Only one of the three lanes can be in Command Mode
- The **command lane** performs the following functions:
 - Receives proposed surface commands from the other two PFC Channels
 - Median Select of the three inputs
 - The output of the median is sent as **Selected Surface Command**
- PFC lanes in **Monitor mode** perform ‘Selected Output’ **monitoring of their command lane**
- PFC **Command lane** performs ‘Selected Output’ **monitoring of other two PFC Channels.**
- The **median select** provides:
 - Fault Blocking against PFC faults until completion of fault detection & identification.
 - Reconfiguration via the PFC cross-lane monitoring.
- The PFC Command lane is inhibited via the cross-lane inhibit hardware logic.
- The faulty PFC Channel is inhibited via the cross-channel inhibit hardware logic.

777 PFC Channel Command/Monitor Architecture

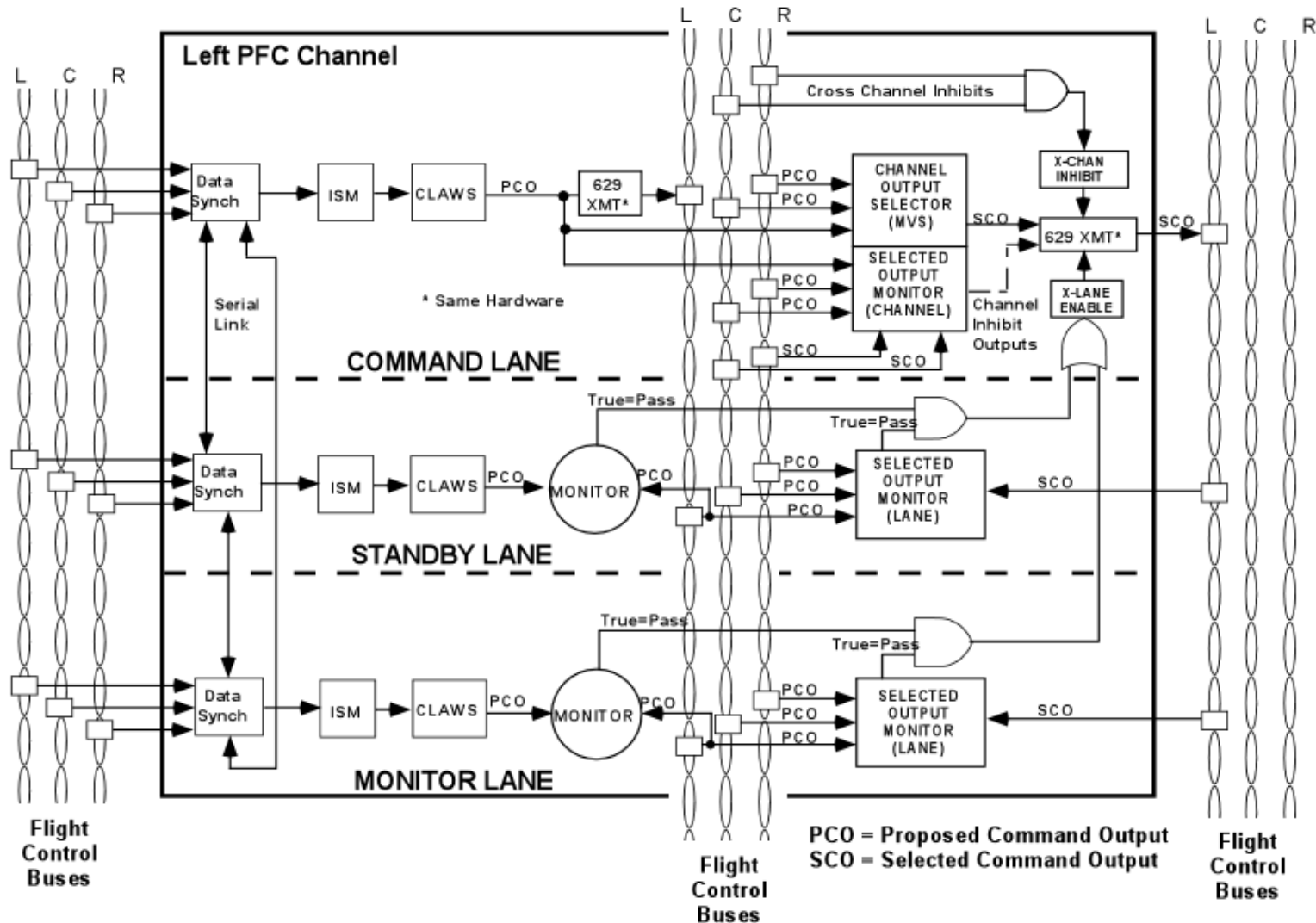

Software “Size”

Function (or “partition”)	Commercial FBW	Military FBW
Control Laws	25 – 30%	40%
Redundancy Management	60-70%	50%
Continuous BIT (not pre-flight)	10%	10%

Redundancy Management is more complex
(and challenging to design) than the control laws !

777 PFC-ACE Signal Path

